



GB-Video-RR

3Gbps Video SFP Optical Receiver, PIN photodetector

Features

- ◆ HD-SDI SFP Receiver available
- ◆ SD-SDI SFP Receiver available
- ◆ 3G-SDI SFP Receiver available
- ◆ SMPTE 297-2006 Compatible.
- ◆ Metal enclosure for Lower EMI
- ◆ PIN photodetector
- ◆ Supports video pathological patterns for SD-SDI, HD-SDI and 3G-SDI
- ◆ Compliant with SFP MSA and SFF-8472 with duplex LC receptacle
- ◆ Digital Diagnostic functions available through the I2C interface
- ◆ Compatible with RoHS
- ◆ +3.3V single power supply
- ◆ Operating case temperature:
Standard : 0 to +70°C

Applications

- ◆ SMPTE 297-2006 Compatible Electrical-to-Optical Interfaces.
- ◆ HDTV/SDTV Service Interfaces.

Description

The video series transceivers are high performance, cost effective modules for duplex video transmission application over single mode fiber.

The receiver is designed to receive data rates from 50Mbps to 2.97Gbps and is specifically

designed for robust performance in the presence of SDI pathological patterns for SMPTE 259M, SMPTE 344M, SMPTE 292M and SMPTE 424M serial rates. The module is fully compliant with SMPTE 297M-2006.

The receiver is consists of two sections: a PIN photodiode integrated with a trans-impedance preamplifier (TIA) and MCU control unit. All modules satisfy class I laser safety requirements.

The receivers are compatible with SFP Multi-Source Agreement (MSA) and SFF-8472. For further information, please refer to SFP MSA.

Absolute Maximum Ratings

Table 1 - Absolute Maximum Ratings

Parameter	Symbol	Min	Max	Unit
Supply Voltage	Vcc	-0.5	4.5	V
Storage Temperature	Ts	-40	+85	°C
Operating Humidity	-	5	85	%

Recommended Operating Conditions

Table 2 - Recommended Operating Conditions

Parameter	Symbol	Min	Typical	Max	Unit
Operating Case Temperature	Tc	0		+70	°C
					°C
Power Supply Voltage	Vcc	3.13	3.3	3.47	V
Power Supply Current	Icc			150	mA
Data Rate			3		Gbps



Optical and Electrical Characteristics

Table 3 - Optical and Electrical Characteristics

Parameter	Symbol	Min	Typical	Max	Unit	Notes
Receiver						
Rise/Fall Time (20%~80%)	SD-SDI			270		1
	HD-SDI			270	ps	
	3G-SDI			270		
Total Output Jitter	PRBS and colour bar	SD-SDI	70	200	ps	
		HD-SDI	50	135		
	3G-SDI	70	100			
	pathological	SD-SDI	200	300		
		HD-SDI	115			
		3G-SDI	120			
Centre Wavelength	λ_c	1260		1580	nm	
Receiver Sensitivity (PRBS)	SD-SDI			-22	dBm	
	HD-SDI			-22	dBm	
	3G-SDI			-22	dBm	
Receiver Sensitivity (Pathological)	SD-SDI			-20	dBm	
	HD-SDI			-22	dBm	
	3G-SDI			-22	dBm	
Receiver Overload		0			dBm	3
LOS De-Assert	LOS _D			-22	dBm	
LOS Assert	LOS _A	-29			dBm	
LOS Hysteresis		1		4	dB	
Data Output Swing Differential	V _{out}	650	800	1000	mV	2
LOS	High	2.0		V _{cc}	V	

	Low		0.8	V	
--	-----	--	-----	---	--

Notes:

1. Rise and fall times, 20% to 80%, are measured following a fourth-order Bessel-Thompson filter with a bandwidth of 0.75 x clock frequency corresponding to the serial data rate
2. PECL input, internally AC-coupled and terminated.
3. Internally AC-coupled.

Timing and Electrical

Table 4 - Timing and Electrical

Parameter	Symbol	Min	Typical	Max	Unit
LOS Assert Time	t_loss_on			100	µs
LOS De-assert Time	t_loss_off			100	µs
Serial ID Clock Rate	f_serial_clock			280	KHz
MOD_DEF (0:2)-High	V _H	2		V _{cc}	V
MOD_DEF (0:2)-Low	V _L			0.8	V

Diagnostics

Table 5 – Diagnostics Specification

Parameter	Range	Unit	Accuracy	Calibration
Temperature	0 to +70	°C	±3°C	Internal / External
Voltage	3.0 to 3.6	V	±3%	Internal / External
RX Power	-20 to -6	dBm	±3dB	Internal / External

I2C Bus Interface

The I2C bus interface uses the 2-wire serial CMOS E2PROM protocol. The serial interface meets the following specifications:

- 1.Support a maximum clock rate of 280Khz.
2. Input/Output levels comply with LVCMOS/LVTTL or compatible logics.
Low: 0 – 0.8 V
High: 2.0 – 3.3 V
Undefined: 0.8 – 2.0 V

Pin Definitions

Pin Diagram

Top of Board

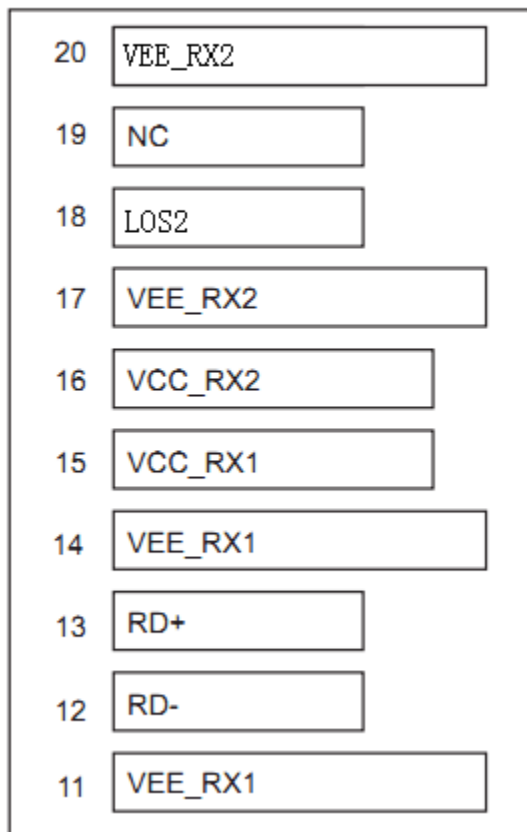

Bottom of Board

(as viewed through top of board)

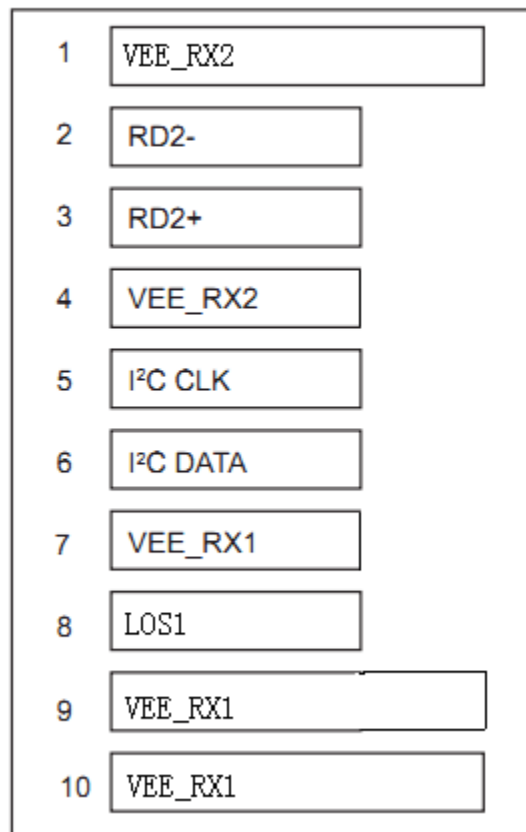

Pin Descriptions

F/2,D Building, Fuxin Industrial Area, 3rd Yangxia Street, Shajin Town, Shenzhen, China

Tel: 86-755-27683696

Fax: 86-755-36652839

v1.1

[Http://www.GB-Link.com](http://www.GB-Link.com)



Pin	Signal Name	Description	Plug Seq.	Notes
1	VEE_TX1	Transmitter 1 Ground	1	
2	TX1_FAULT	Transmitter 1 Fault Indication	3	Note 1
3	NC	Not Connected	3	
4	VEE_TX1	Transmitter 1 Ground	3	
5	I2C CLK	SCL Serial Clock Signal	3	Note 3
6	I2C DATA	SDA Serial Data Signal	3	Note 3
7	VEE_TX2	Transmitter 2 Ground	3	
8	TD2+	Transmit 2 Data In	3	Note 4
9	TD2-	Inv. Transmit 2 Data In	1	Note 4
10	TX2_DIS	Transmitter 2 Disable	1	Note 2
11	VEE_TX2	Transmitter 2 Ground	1	
12	TX2_FAULT	Transmitter 2 Fault Indication	3	Note 1
13	NC	Not Connected	3	
14	VEE_TX2	Transmitter 2 Ground	1	
15	VCC_TX2	Transmitter Power 2 Supply	2	
16	VCC_TX1	Transmitter Power 1 Supply	2	
17	VEE_TX1	Transmitter 1 Ground	1	
18	TD1+	Transmit 1 Data In	3	Note 4
19	TD1-	Inv. Transmit 1 Data In	3	Note 4
20	TX1_DIS	Transmitter 1 Disable	1	Note 2

Notes:

Plug Seq.: Pin engagement sequence during hot plugging.

- 1) These are the module definition pins. They should be pulled up with a 4.7k~10kΩ resistor on the host board. The pull-up voltage shall be VccR.
I2C CLK is the clock line of two wire serial interface for serial ID
I2C DATA is the data line of two wire serial interface for serial ID
- 2) LOS is an open collector output, which should be pulled up with a 4.7k~10kΩ resistor. Pull up voltage between 2.0V and Vcc+0.3V. Logic 1 indicates loss of signal; Logic 0 indicates normal operation. In the low state, the output will be pulled to less than 0.8V.
- 3) RD-/+ : These are the differential receiver outputs. They are internally AC-coupled 100 differential lines which should be terminated with 100Ω (differential) at the user SERDES.

Serial ID Field Memory Map

The module serial Id and calibration information is stored in the E2PROM of the SFP supervising device using the address map.

Byte Addr	Bit Size	Name	Description	Value (hex)
0	1	Identifier	Type of transceiver	82
1	1	Ext. Identifier	Extended identifier of type of transceiver	04
2	1	Connector	Code for connector type	07
3	1	Standards Compliance	For SMPTE259M/344M/292M/424M and SMPTE 297M	41
4	7	Transceiver	Code for electronic or optical compatibility, Not applicable.	
5				
6				
7				
8				
9				
10				
11	1	Encoding	Code for serial encoding algorithm	30
12	1	BR, Nominal	Nominal signalling rate, units of 100MBd.	1E
13	1	Rate Identifier	Type of rate select functionality, Not applicable	
14	1	Length (SMF, km)	Link length supported for single mode fiber, units of km	14
15	1	Length (SMF)	Link length supported for single mode fiber, units of 100 m	00
16	1	Length (50um)	Link length supported for 50 um OM2 fiber, units of 10 m	00
17	1	Length (62.5um)	Link length supported for 62.5 um OM1 fiber, units of 10 m	00



18	1	Length (cable)	Link length supported for copper or direct attach cable, units of m	00
19	1	Length (OM3)	Link length supported for 50 um OM3 fiber, units of 10 m	00
20	16	Vendor name	SFP vendor name (ASCII)	X
21				X
22				X
23				X
24				X
25				X
26				X
27				X
28				X
29				X
30				X
31				X
32				X
33				X
34				X
35				X
36	1	Reserved	Reserved	00
37	3	Vendor OUI	SFP vendor IEEE company ID	00
38				00
39				00
40	16	Vendor PN	Part number provided by SFP vendor (ASCII)	X
41				X
42				X
43				X
44				X
45				X
46				X
47				X



48				X
49				X
50				X
51				X
52				X
53				X
54				X
55				
56	4	Vendor rev	Revision level for part number provided by vendor (ASCII)	X
57				
58				
59				
60	2	Wavelength	Laser wavelength (Passive/Active Cable Specification Compliance)	
61				
62	1	Unallocated		
63	1	CC_BASE	Check code for Base ID Fields	
64	2	Options	Indicates which optional transceiver signals are implemented	
65				
66	1	BR, max	Upper bit rate margin, units of %	05
67	1	BR, min	Lower bit rate margin, units of %	5F
68	16	Vendor SN	Serial number provided by vendor (ASCII)	X
69				X
70				X
71				X
72				X
73				X
74				X
75				X
76				X
77				X
78				X
79				X



80				X
81				X
82				X
83				X
84	8	Date code	Vendor' s manufacturing date code	
85				
86				
87				
88				
89				
90				
91				
92	1	Diagnostic Monitoring Type	Indicates which type of diagnostic monitoring is implemented(if any) in the transceiver	28
93	1	Enhanced Options	Indicates which optional enhanced features are implemented(if any) in the transceiver	90
94	1	SFF-8472Compliance	Indicates which revision of SFF-8472 the transceiver complies with.	X
95	1	CC_EXT	Check code for the Extended ID Fields	
96	32	Vendor Specific	Vendor Specific EEPROM	0
97				0
98				0
99				0
100				0
101				0
102				0
103				0
104				0
105				0
106				0
107				0
108				0
109				0
110				0
111				0
112				0



113				0
114				0
115				0
116				0
117				0
118				0
119				0
120				0
121				0
122				0
123				0
124				0
125				0
126				0
127				0

Digital Diagnostic Monitoring Interface (2-Wire Address A2H)

Byte Addr	Bit Size	Name	Description and Value of the Field
00-01	2	Temp High Alarm	MSB at lower address. 100° C
02-03	2	Temp Low Alarm	MSB at lower address. -50° C
04-05	2	Temp High Warning	MSB at lower address. 95° C
06-07	2	Temp Low Warning	MSB at lower address. -45° C
08-09	2	Voltage High Alarm	MSB at lower address. 3.7V
10-11	2	Voltage Low Alarm	MSB at lower address. 2.9V
12-13	2	Voltage High Warning	MSB at lower address. 3.6V
14-15	2	Voltage Low Warning	MSB at lower address. 3.0V
16-17	2	Bias High Alarm	MSB at lower address. 70mA
18-19	2	Bias Low Alarm	MSB at lower address. 8mA
20-21	2	Bias High Warning	MSB at lower address. 65mA



22-23	2	Bias Low Warning	MSB at lower address. 9mA
24-25	2	RX2 Power High Alarm	MSB at lower address. 1dBm
26-27	2	RX2 Power Low Alarm	MSB at lower address. -25dBm
28-29	2	RX2 Power High Warning	MSB at lower address. 0dBm
30-31	2	RX2 Power Low Warning	MSB at lower address. -24dBm
32-33	2	RX1 Power High Alarm	MSB at lower address. 1dBm
34-35	2	RX1 Power Low Alarm	MSB at lower address. -25dBm
36-37	2	RX1 Power High Warning	MSB at lower address. 0dBm
38-39	2	RX1 Power Low Warning	MSB at lower address. -24dBm
40-55	16	Reserved	Reserved
56-59	4		
60-63	4		
64-67	4		
68-71	4		
72-75	4		
76-77	2	TX_I (Slope)	Set to 1 for “internally calibrated” devices.Value is 01 00.
78-79	2	TX_I (Offset)	Set to zero for “internally calibrated” devices.Value is 00 00.
80-81	2	TX_PWR (Slope)	Set to 1 for “internally calibrated” devices.Value is 01 00.
82-83	2	TX_PWR (Offset)	Set to zero for “internally calibrated” devices.Value is 00 00.
84-85	2	T (Slope)	Set to 1 for “internally calibrated” devices.Value is 01 00.
86-87	2	T (Offset)	Set to zero for “internally calibrated” devices.Value is 00 00.



88-89	2	V (Slope)	Set to 1 for “internally calibrated” devices.Value is 01 00.
90-91	2	V (Offset)	Set to zero for “internally calibrated” devices.Value is 00 00.
92-94	3	Reserved	Reserved
95	1	Checksum	Checksum of bytes 0 - 94.
96-97	2	Temperature (MSB, LSB)	Internally measured module temperature
98-99	2	Supply Voltage (MSB, LSB)	Internally measured supply voltage in module
100-101	2	Bias1() (MSB, LSB)	Internally measured module bias1
102-103	2	Tx1 Power (MSB, LSB)	Internally measured Tx1 Power Current
104-105	2	Tx2 Power (MSB, LSB)	Internally Measured Tx2 Power Current
106-107	2	Bias2() (MSB, LSB)	Internally measured module bias2
108-109	2	Reserved	Reserved
110	Bit7	Tx Disable State	Digital state of the TX Disable Input Pin.
110	Bit6	Soft Tx Disable	Bit 6
110	Bit5-3	Reserved	
110	Bit2	Tx Fault	Bit 2
110	Bit1		Bit1
110	Bit0	Data_Ready	Bit 0
111	1	Reserved	Reserved
112	1		
113	1		
114-115	Reserved		Reserved
116	1		

117	1		
118-119	2	Reserved	Reserved
120-127	8	Vendor specific	
128-247	120	User EEPROM	User writable EEPROM
248-255	8	Vendor Specific	Vendor specific control functions

Mechanical Dimensions

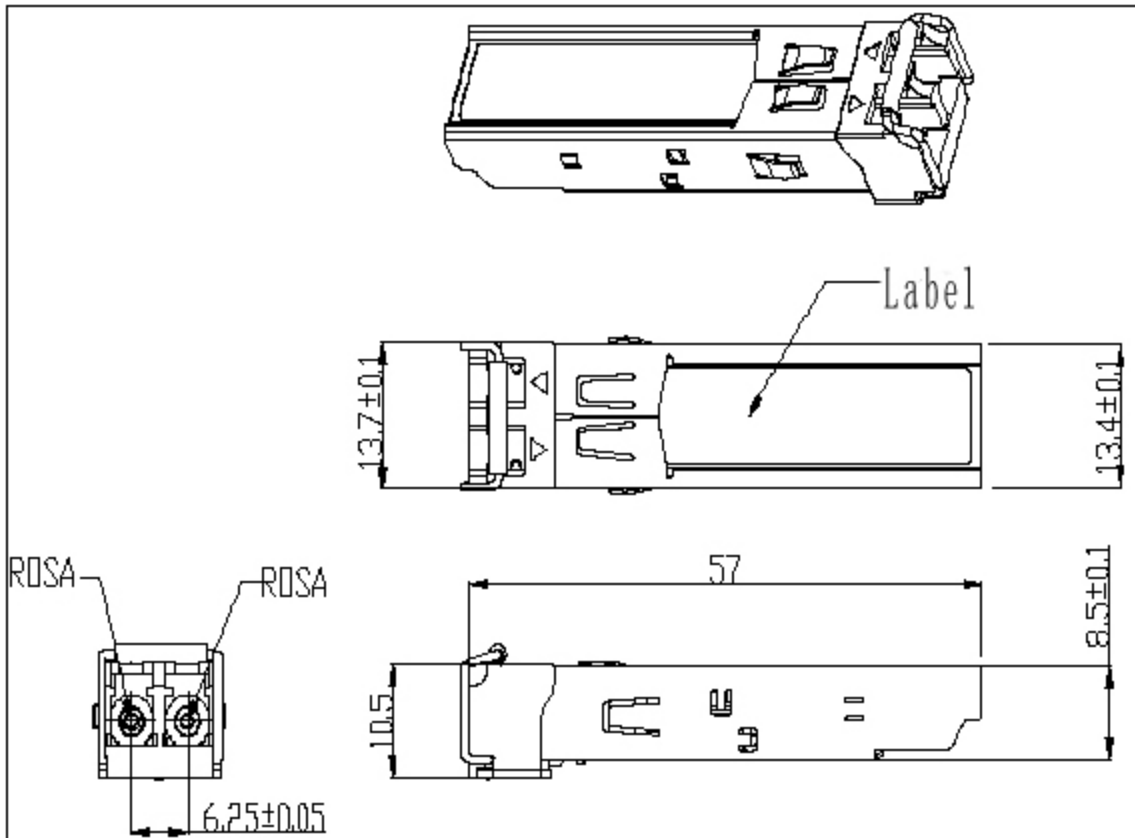

Ordering information

F/2,D Building, Fuxin Industrial Area, 3rd Yangxia Street, Shajin Town, Shenzhen, China

Tel: 86-755-27683696

Fax: 86-755-36652839

[Http://www.GB-Link.com](http://www.GB-Link.com)



深圳市光辉通信技术有限公司
Shenzhen GB-Link Technology Co., LTD
[Http://www.GB-Link.com](http://www.GB-Link.com)

15

Part Number	Product Description
GB-Video-RR	PIN, 3Gbps, 0°C ~ +70°C, With Digital Diagnostic Monitoring

E-mail: sales@GB-Link.com
Web : <http://www.GB-Link.com>

F/2,D Building, Fuxin Industrial Area, 3rd Yangxia Street, Shajin Town, Shenzhen, China

Tel: 86-755-27683696

Fax: 86-755-36652839

v1.1

[Http://www.GB-Link.com](http://www.GB-Link.com)