GB-Video-TT-40

3Gbps Video SFP Optical Transmitter, 40km Reach

Features

- ◆ HD-SDI SFP Transmitter available
- ◆ SD-SDI SFP Transmitter available
- ◆ 3G-SDI SFP Transmitter available
- ◆ SMPTE 297-2006 Compatible.
- ◆ Metal enclosure for Lower EMI
- ◆ 1310nm DFB Laser
- ◆ Supports video pathological patterns for SD-SDI, HD-SDI and 3G-SDI
- ◆ Compliant with SFP MSA and SFF-8472 with duplex LC receptacle
- ◆ Digital Diagnostic functions available through the I2C interface
- ◆ Compatible with RoHS
- ◆ +3.3V single power supply
- ◆ Operating case temperature:
Standard : 0 to +70°C



Applications

- ◆ SMPTE 297-2006 Compatible Electrical-to-Optical Interfaces.
- ◆ HDTV/SDTV Service Interfaces.

Description

The video series transceivers are high performance, cost effective modules for duplex video transmission application over single mode fiber.

The Transmitter is designed to transmit data rates from 50Mbps to 2.97Gbps and is specifically



designed for robust performance in the presence of SDI pathological patterns for SMPTE 259M, SMPTE 344M, SMPTE 292M and SMPTE 424M serial rates. The module is fully compliant with SMPTE 297M-2006.

The transmitter is a dual channel optical transmitter module ,one channel consists of two sections: a DFB laser transmitter and MCU control unit. All modules satisfy class I laser safety requirements.

The transceivers are compatible with SFP Multi-Source Agreement (MSA) and SFF-8472. For further information, please refer to SFP MSA.

Absolute Maximum Ratings

Parameter	Symbol	Min	Max	Unit
Supply Voltage	Vcc	-0.5	4.5	V
Storage Temperature	Ts	-40	+85	°C
Operating Humidity	-	5	85	%

Recommended Operating Conditions

Parameter	Symbol	Min	Typical	Max	Unit
Operating Case Temperature	Standard	0		+70	°C
					°C
Power Supply Voltage	Vcc	3.13	3.3	3.47	V
Power Supply Current	Icc			500	mA
Data Rate			3		Gbps

Optical and Electrical Characteristics

Parameter	Symbol	Min	Typical	Max	Unit	Notes
Transmitter						
Centre Wavelength	λ_c	1260	1310	1360	nm	



Spectral Width (-20dB)		σ			1	nm	
Side Mode Suppression Ratio		SMSR	30			dB	
Average Output Power		Pout	-2	0	+3	dBm	1
Extinction Ratio		ER	8	10		dB	
Rise/Fall Time (20%~80%)		SD-SDI			270	ps	2
		HD-SDI			270		
		3G-SDI			270		
Total Output Jitter	PRBS and colour bar	SD-SDI		70	200	ps	
		HD-SDI		50	135		
		3G-SDI		70	100		
	pathological	SD-SDI		200	300		
		HD-SDI		115			
		3G-SDI		120			
Data Input Swing Differential		V_{IN}	400		1800	mV	3
Input Differential Impedance		Z_{IN}	90	100	110	Ω	
TX Disable	Disable		2.0		Vcc	V	
	Enable		0		0.8	V	
TX Fault	Fault		2.0		Vcc	V	
	Normal		0		0.8	V	

Notes:

1. The optical power is launched into SMF.
2. Rise and fall times, 20% to 80%, are measured following a fourth-order Bessel-Thompson filter with a bandwidth of 0.75 x clock frequency corresponding to the serial data rate
3. PECL input, internally AC-coupled and terminated.
4. Internally AC-coupled.

Timing and Electrical

Parameter	Symbol	Min	Typical	Max	Unit
-----------	--------	-----	---------	-----	------

Tx Disable Negate Time	t_on			1	ms
Tx Disable Assert Time	t_off			10	μs
Time To Initialize, including Reset of Tx Fault	t_init			300	ms
Tx Fault Assert Time	t_fault			100	μs
Tx Disable To Reset	t_reset	10			μs
Serial ID Clock Rate	f_serial_clock			280	KHz
MOD_DEF (0:2)-High	V _H	2		V _{cc}	V
MOD_DEF (0:2)-Low	V _L			0.8	V

Diagnostics Specification

Parameter	Range	Unit	Accuracy	Calibration
Temperature	0 to +70	°C	±3°C	Internal / External
Voltage	3.0 to 3.6	V	±3%	Internal / External
Bias Current	0 to 100	mA	±10%	Internal / External
TX Power	-5 to 0	dBm	±3dB	Internal / External

I2C Bus Interface

The I2C bus interface uses the 2-wire serial CMOS E2PROM protocol. The serial interface meets the following specifications:

- 1.Support a maximum clock rate of 280Khz.
2. Input/Output levels comply with LVCMOS/LVTTL or compatible logics.

Low: 0 – 0.8 V

High: 2.0 – 3.3 V

Undefined: 0.8 – 2.0 V

Pin Definitions

Pin Diagram

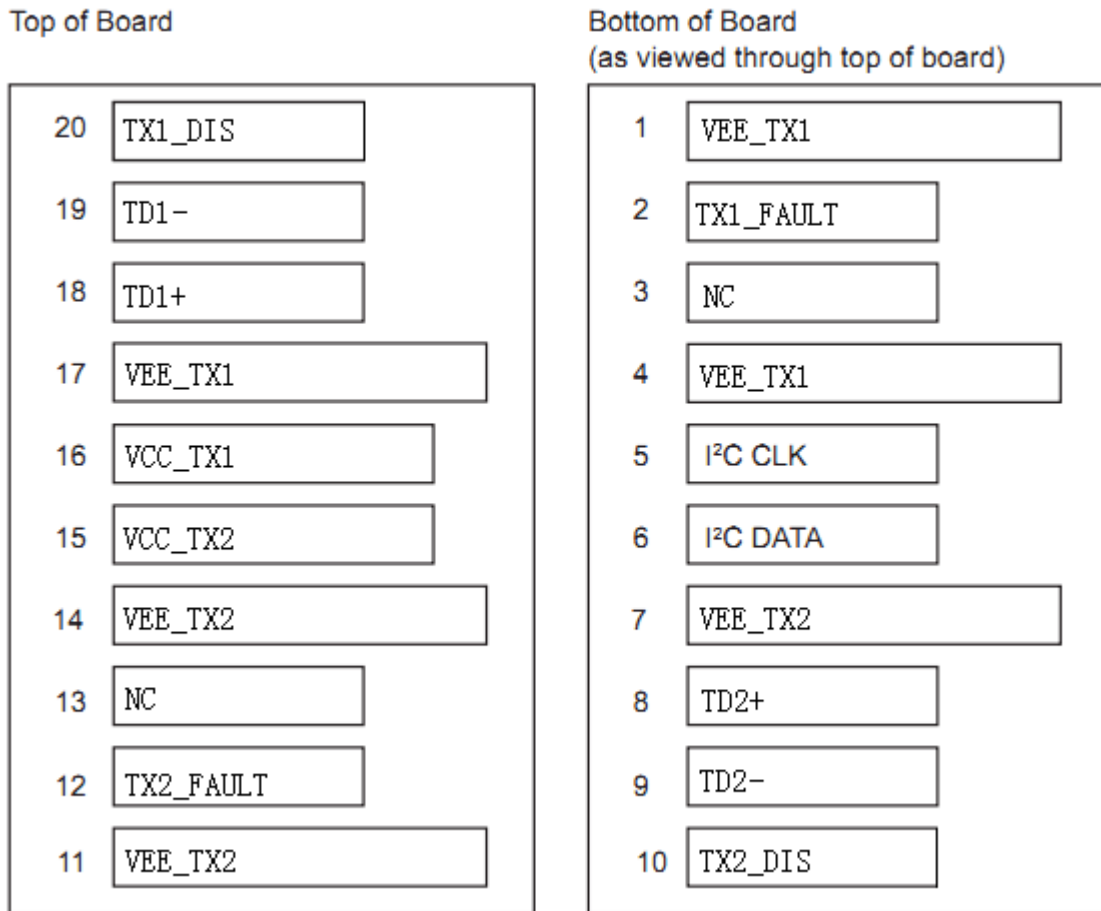

Pin Descriptions

Pin	Signal Name	Description	Plug Seq.	Notes
1	VEE_TX1	Transmitter 1 Ground	1	
2	TX1_FAULT	Transmitter 1 Fault Indication	3	Note 1
3	NC	Not Connected	3	



4	VEE_TX1	Transmitter 1 Ground	3	
5	I2C CLK	SCL Serial Clock Signal	3	Note 3
6	I2C DATA	SDA Serial Data Signal	3	Note 3
7	VEE_TX2	Transmitter 2 Ground	3	
8	TD2+	Transmit 2 Data In	3	Note 4
9	TD2-	Inv. Transmit 2 Data In	1	Note 4
10	TX2_DIS	Transmitter 2 Disable	1	Note 2
11	VEE_TX2	Transmitter 2 Ground	1	
12	TX2_FAULT	Transmitter 2 Fault Indication	3	Note 1
13	NC	Not Connected	3	
14	VEE_TX2	Transmitter 2 Ground	1	
15	VCC_TX2	Transmitter Power 2 Supply	2	
16	VCC_TX1	Transmitter Power 1 Supply	2	
17	VEE_TX1	Transmitter 1 Ground	1	
18	TD1+	Transmit 1 Data In	3	Note 4
19	TD1-	Inv. Transmit 1 Data In	3	Note 4
20	TX1_DIS	Transmitter 1 Disable	1	Note 2

Notes:

Plug Seq.: Pin engagement sequence during hot plugging.

- 1) TX Fault is an open collector output, which should be pulled up with a 4.7k~10kΩ resistor on the host board to a voltage between 2.0V and Vcc+0.3V. Logic 0 indicates normal operation; Logic 1 indicates a laser fault of some kind. In the low state, the output will be pulled to less than 0.8V.
- 2) TX Disable is an input that is used to shut down the transmitter optical output. It is pulled up within the module with a 4.7k~10kΩ resistor. Its states are:
Low (0 to 0.8V): Transmitter on
(>0.8V, < 2.0V): Undefined
High (2.0 to 3.465V): Transmitter Disabled
Open: Transmitter Disabled
- 3) They should be pulled up with a 4.7k~10kΩ resistor on the host board. The pull-up voltage shall be VCC_TX1 or VCC_TX2.
I2C CLK is the clock line of two wire serial interface for serial ID
I2C DATA is the data line of two wire serial interface for serial ID
- 4) TD1/2-/+ : These are the differential transmitter inputs. They are internally AC-coupled, differential lines with 100Ω differential termination inside the module.

Serial ID Field Memory Map

The module serial Id and calibration information is stored in the E2PROM of the SFP supervising device using the address map.

Byte Addr	Bit Size	Name	Description	Value (hex)
0	1	Identifier	Type of transceiver	82
1	1	Ext. Identifier	Extended identifier of type of transceiver	04
2	1	Connector	Code for connector type	07
3	1	Standards Compliance	For SMPTE259M/344M/292M/424M and SMPTE 207M	41
4	7	Transceiver	Code for electronic or optical compatibility, Not applicable.	
5				
6				
7				
8				
9				
10				
11	1	Encoding	Code for serial encoding algorithm	30
12	1	BR, Nominal	Nominal signalling rate, units of 100MBd.	1E
13	1	Rate Identifier	Type of rate select functionality, Not applicable	
14	1	Length(SMF,km)	Link length supported for single mode fiber, units of km	14
15	1	Length (SMF)	Link length supported for single mode fiber, units of 100 m	00
16	1	Length (50um)	Link length supported for 50 um OM2 fiber, units of 10 m	00
17	1	Length (62.5um)	Link length supported for 62.5 um OM1 fiber, units of 10 m	00
18	1	Length (cable)	Link length supported for copper or direct attach cable, units of m	00
19	1	Length (OM3)	Link length supported for 50 um OM3 fiber, units of 10 m	00



20				X
21				X
22				X
23				X
24				X
25				X
26				X
27	16	Vendor name	SFP vendor name (ASCII)	X
28				X
29				X
30				X
31				X
32				X
33				X
34				X
35				X
36	1	Reserved	Reserved	00
37				00
38	3	Vendor OUI	SFP vendor IEEE company ID	00
39				00
40	16	Vendor PN	Part number provided by SFP vendor (ASCII)	X
41				X
42				X
43				X
44				X
45				X
46				X
47				X
48				X
49				X
50				X



51				X
52				X
53				X
54				X
55				
56	4	Vendor rev	Revision level for part number provided by vendor (ASCII)	X
57				
58				
59				
60	2	Wavelength	Laser wavelength (Passive/Active Cable Specification Compliance)	
61				
62	1	Unallocated		
63	1	CC_BASE	Check code for Base ID Fields	
64	2	Options	Indicates which optional transceiver signals are implemented	
65				
66	1	BR, max	Upper bit rate margin, units of %	05
67	1	BR, min	Lower bit rate margin, units of %	5F
68	16	Vendor SN	Serial number provided by vendor (ASCII)	X
69				X
70				X
71				X
72				X
73				X
74				X
75				X
76				X
77				X
78				X
79				X
80				X
81				X
82				X



83				X
84	8	Date code	Vendor's manufacturing date code	
85				
86				
87				
88				
89				
90				
91				
92	1	Diagnostic Monitoring Type	Indicates which type of diagnostic monitoring is implemented(if any) in the transceiver	28
93	1	Enhanced Options	Indicates which optional enhanced features are implemented(if any) in the transceiver	90
94	1	SFF-8472Compliance	Indicates which revision of SFF-8472 the transceiver complies with.	X
95	1	CC_EXT	Check code for the Extended ID Fields	
96	32	Vendor Specific	Vendor Specific EEPROM	0
97				0
98				0
99				0
100				0
101				0
102				0
103				0
104				0
105				0
106				0
107				0
108				0
109				0
110				0
111				0
112				0
113				0
114				0
115				0



116				0
117				0
118				0
119				0
120				0
121				0
122				0
123				0
124				0
125				0
126				0
127				0

Digital Diagnostic Monitoring Interface (2-Wire Address A2H)

Byte Addr	Bit Size	Name	Description and Value of the Field
00-01	2	Temp High Alarm	MSB at lower address. 100°C
02-03	2	Temp Low Alarm	MSB at lower address. -50°C
04-05	2	Temp High Warning	MSB at lower address. 95°C
06-07	2	Temp Low Warning	MSB at lower address. -45°C
08-09	2	Voltage High Alarm	MSB at lower address. 3.7V
10-11	2	Voltage Low Alarm	MSB at lower address. 2.9V
12-13	2	Voltage High Warning	MSB at lower address. 3.6V
14-15	2	Voltage Low Warning	MSB at lower address. 3.0V
16-17	2	Bias High Alarm	MSB at lower address. 70mA
18-19	2	Bias Low Alarm	MSB at lower address. 8mA
20-21	2	Bias High Warning	MSB at lower address. 65mA
22-23	2	Bias Low Warning	MSB at lower address. 9mA
24-25	2	TX1 Power High Alarm	MSB at lower address. 4dBm



26-27	2	TX1 Power Low Alarm	MSB at lower address. -6dBm
28-29	2	TX1 Power High Warning	MSB at lower address. 3dBm
30-31	2	TX1 Power Low Warning	MSB at lower address. -5dBm
32-33	2	TX2 Power High Alarm	MSB at lower address. 4dBm
34-35	2	TX2 Power Low Alarm	MSB at lower address. -6dBm
36-37	2	TX2 Power High Warning	MSB at lower address. 3dBm
38-39	2	TX2 Power Low Warning	MSB at lower address. -5dBm
40-55	16	Reserved	Reserved
56-59	4		
60-63	4		
64-67	4		
68-71	4		
72-75	4		
76-77	2	TX_I (Slope)	Set to 1 for “internally calibrated” devices. Value is 01 00.
78-79	2	TX_I (Offset)	Set to zero for “internally calibrated” devices. Value is 00 00.
80-81	2	TX_PWR (Slope)	Set to 1 for “internally calibrated” devices. Value is 01 00.
82-83	2	TX_PWR (Offset)	Set to zero for “internally calibrated” devices. Value is 00 00.
84-85	2	T (Slope)	Set to 1 for “internally calibrated” devices. Value is 01 00.
86-87	2	T (Offset)	Set to zero for “internally calibrated” devices. Value is 00 00.
88-89	2	V (Slope)	Set to 1 for “internally calibrated” devices. Value is 01 00.
90-91	2	V (Offset)	Set to zero for “internally calibrated” devices. Value is 00 00.
92-94	3	Reserved	Reserved



95	1	Checksum	Checksum of bytes 0 – 94.
96-97	2	Temperature (MSB, LSB)	Internally measured module temperature
98-99	2	Supply Voltage (MSB, LSB)	Internally measured supply voltage in module
100-101	2	Bias1()(MSB, LSB)	Internally measured module bias1
102-103	2	Tx1 Power(MSB, LSB)	Internally measured Tx1 Power Current
104-105	2	Tx2 Power (MSB, LSB)	Internally Measured Tx2 Power Current
106-107	2	Bias2()(MSB, LSB)	Internally measured module bias2
108-109	2	Reserved	Reserved
110	Bit7	Tx Disable State	Digital state of the TX Disable Input Pin.
110	Bit6	Soft Tx Disable	Bit 6
110	Bit5-Bit3	Reserved	
110	Bit2	Tx Fault	Bit 2
110	Bit1		Bit1
110	Bit0	Data_Ready	Bit 0
111	1	Reserved	Reserved
112	1		
113	1		
114-115	Reserved		Reserved
116	1		
117	1		
118-119	2	Reserved	Reserved
120-127	8	Vendor specific	
128-247	120	User EEPROM	User writable EEPROM

248-255	8	Vendor Specific	Vendor specific control functions
---------	---	-----------------	-----------------------------------

Mechanical Dimensions

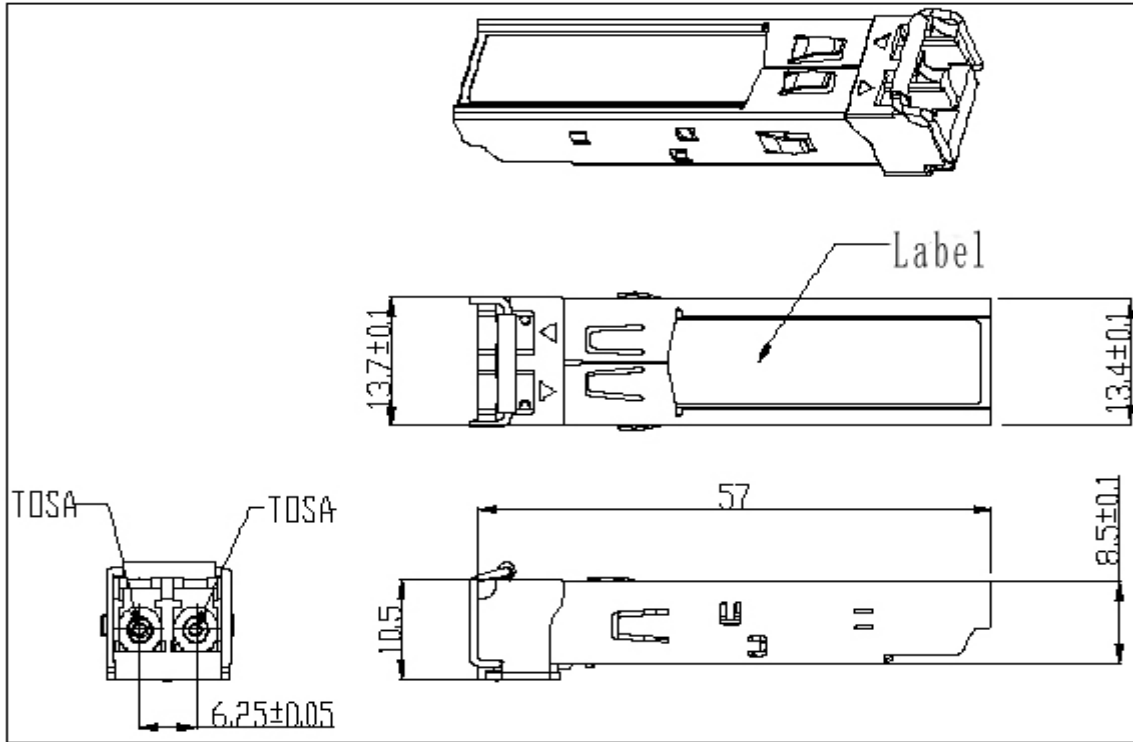

Ordering information

Part Number	Product Description
GB-Video-TT-40	1310nm, 3Gbps, 40km, $0^{\circ}\text{C} \sim +70^{\circ}\text{C}$, With Digital Diagnostic Monitoring

E-mail: sales@GB-Link.com
 Web : <http://www.GB-Link.com>