



GB-GPON-ONU-1-2G

GPON SFP ONU Transceiver

Features

- ◆ Single fiber Bi-Directional transceiver with single mode SC receptacle
- ◆ 1310nm burst-mode 1.25Gbps transmitter with DFB laser
- ◆ 1490nm continuous-mode 2.5Gbps receiver with APD-TIA
- ◆ Meets ITU-T G.984.2 Class C+
- ◆ Digital diagnostic interface compliant with SFF-8472 Rev 9.4 ,
Digital Diagnostic Monitoring (DDM) with external calibration
- ◆ 3.3V Single power supply
 - LVPECL interface logic level for data input
 - CML interface logic level for data output
 - Differential line input/output impedance 100 ohm
 - LVTTL for burst signal input and signal detect output
- ◆ Complies with RoHS directive (2002/95/EC)
- ◆ Operating case temperature:
Standard : 0 to +70°C

Applications

- ◆ Gigabit Passive Optical Network (GPON) ONU

Description

GB-GPON-ONU-1-2G transceiver is a high performance module for single fiber communications using a 1310nm burst-mode transmitter and a 1490nm continuous-mode receiver. It is used in the optical network terminal (ONT) for GPON ONT Class C+ applications.

The Transmitter is designed for single mode fiber and operates at a nominal wavelength of 1310nm. The transmitter module uses a DFB laser diode with full IEC825 and CDRH class 1 eye safety. It contains APC functions, a temperature compensation circuit to ensure compliance with G.984.2

requirement at operating temperature, LVPECL data inputs and DC coupling circuit.

The receiver section uses a hermetic packaged APD TIA (APD with trans-impedance amplifier) and a limiting amplifier. The APD converts optical power into electrical current and the current is transformed to voltage by the trans-impedance amplifier. The differential DATA and /DATA CML data signals are produced by the limiting amplifier. The APD TIA is AC coupled to the limiting amplifier through a low pass filter. As the optical input power decreases, the Signal Detect will switch from high to low (de-assert point). As the optical input power is increases, Signal Detect will switch back from low to high (assert point). The assert level is at least 0.5 dB higher than the de-assert level (Signal Detect Hysteresis).

Absolute Maximum Ratings

Parameter	Symbol	Min.	Max.	Units	Notes
Storage Temperature	Tst	-40	+85	°C	-
Operating Case Temperature	Tc	0	70	°C	-
Operating Humidity	RH	5	90	%	Non-condensing
Input Voltage	-	GND	Vcc	V	-
Power Supply Voltage	Vcc-Vee	0	3.6	V	-

Recommended Operating Conditions

Parameter	Symbol	Min	Typical	Max	Unit
Operating Case Temperature	Standard Tc	0	-	+70	°C
Power Supply Voltage	Vcc	3.13	3.3	3.47	V
Power Supply Current	Icc	-	-	500	mA

Optical and Electrical Characteristics

Parameter	Symbol	Min	Typical	Max	Unit	Notes
Transmitter						
Tx Data Rate	R _T	-	1.25	-	Gb/S	-



Centre Wavelength	λ_c	1260	1310	1360	nm	-
Spectral Width	$\Delta\lambda$	-	-	1	nm	-
Side Mode Suppression Ratio	SMSR	30	-	-	dB	-
Average Output Power	P _{out}	2	-	7	dBm	1
Extinction Ratio	ER	10	-	-	dB	-
Burst Enable Delay	T _{on}	-	-	12.86	ns	
Burst Disable Delay	T _{off}	-	-	12.86	ns	
Average Launch Power-OFF Transmitter	P _{off}			-41	dBm	
Optical Rise/Fall Time (20%~80%)	tr/tf			260	ps	
Data Input Swing Differential	V _{IN}	200		1600	mV	2
Input Differential Impedance	Z _{IN}	90	100	110	Ω	
Burst	Disable		2.0	V _{cc}	V	
	Enable		0	0.8	V	
TX Fault	Fault		2.0	V _{cc}	V	
	Normal		0	0.8	V	
Receiver						
Rx Data Rate	R _R	-	2.5	-	Gb/s	3
Centre Wavelength	λ_c	1480		1500	nm	
Receiver Sensitivity(BOL)	Sen			-30	dBm	3
Receiver Overload	Sat	-8			dBm	3
Receiver Reflectance				-20	dB	
Signal Detect De-Assert	SDD	-44			dBm	
Signal Detect Assert	SDA			-31	dBm	
Signal Detect Hysteresis	SDH	0.5		6	dB	
Output Differential Impedance	Z _{IN}	90	100	110	Ω	
Data Output Swing Differential	V _{out}	400		1000	mV	

SD Output Voltage	High		2.0		Vcc	V	
	Low		0		0.8	V	

Notes:

1. The optical power is launched into SMF.
2. PECL input, internally DC-coupled and terminated.
3. Measured with a PRBS 2^7-1 test pattern @1250Mbps, BER $\leq 1 \times 10^{-10}$.

Diagnostics Specification

Parameter	Range	Unit	Accuracy	Calibration
Temperature	0 to +70	°C	±3°C	Internal / External
Voltage	3.0 to 3.6	V	±3%	Internal / External
Bias Current	0 to 100	mA	±10%	Internal / External
TX Power	2 to 7	dBm	±3dB	Internal / External
RX Power	-30 to -8	dBm	±3dB	Internal / External

Transmitter Burst Mode Timing Characteristics

Definition of Burst Enable Delay (T_{on}) and Burst Disable Delay (T_{off})

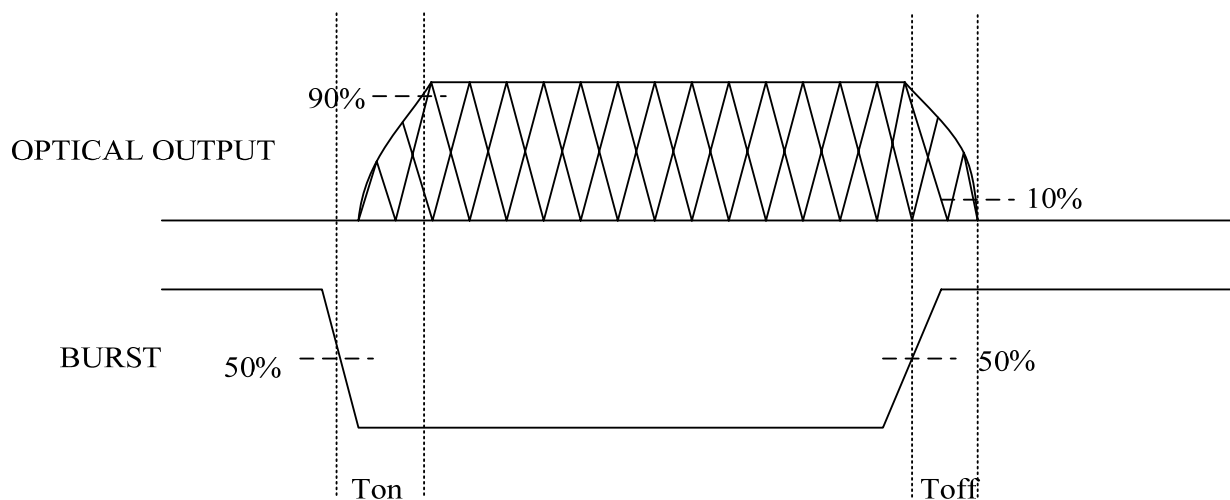

Digital Diagnostic Memory Map

The transceivers provide serial ID memory contents and diagnostic information about the present operating conditions by the 2-wire serial interface (SCL, SDA).

The diagnostic information with internal calibration or external calibration all are implemented, including received power monitoring, transmitted power monitoring, bias current monitoring, supply voltage monitoring and temperature monitoring.

The digital diagnostic memory map specific data field defines as following.

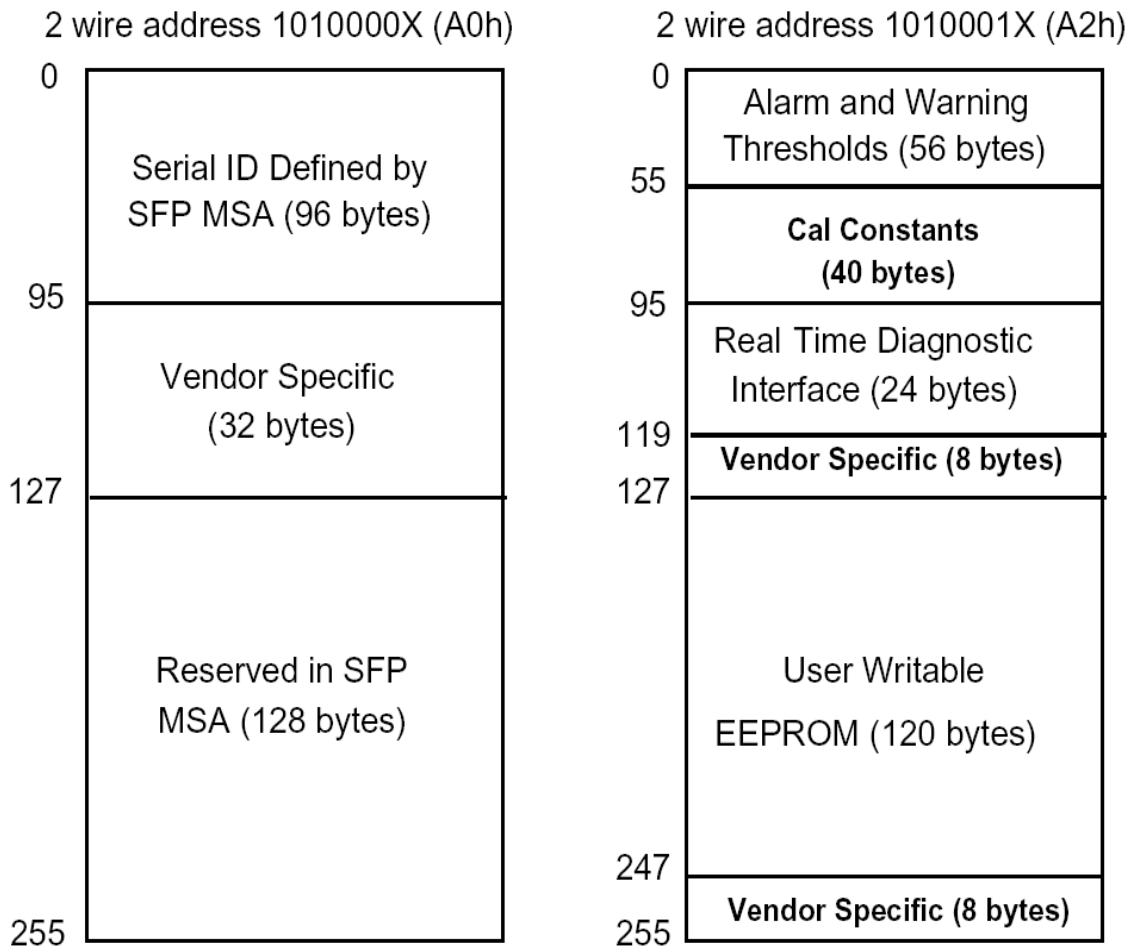

Pin Definitions

Pin Diagram

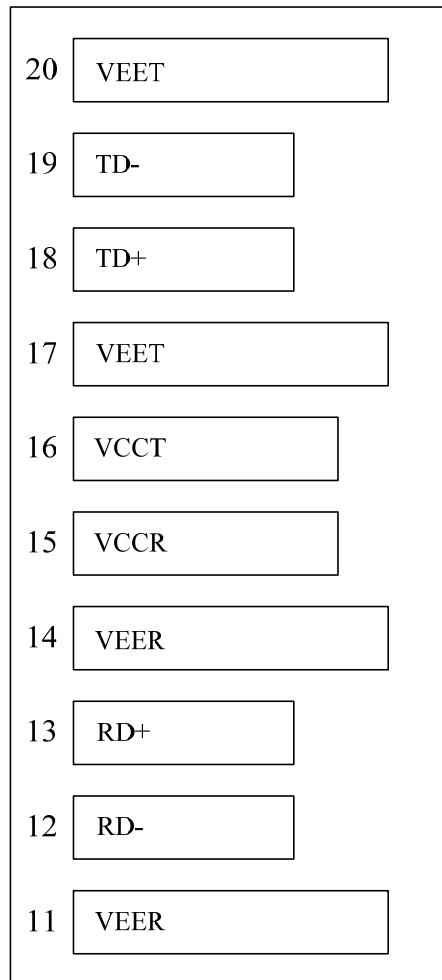

Top of Board

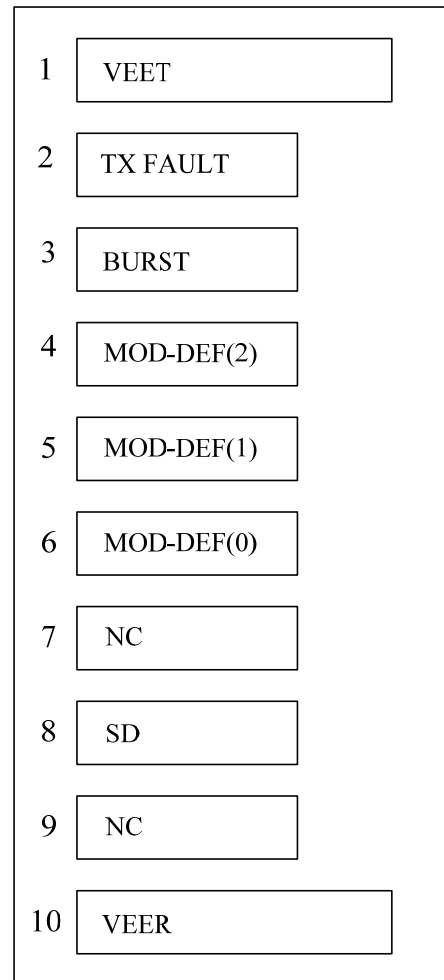

Bottom of Board

Pin Descriptions

Pin	Signal Name	Description	Plug Seq.	Notes
1	V _{EET}	Transmitter Ground	1	
2	TX FAULT	Transmitter Fault Indication	3	Note 1
3	BURST	Burst Single	3	Note 2
4	MOD_DEF(2)	SDA Serial Data Signal	3	Note 3
5	MOD_DEF(1)	SCL Serial Clock Signal	3	Note 3
6	MOD_DEF(0)	TTL Low	3	Note 3
7	-	-	3	
8	SD	Signal Detect Output	3	Note 4
9	-	-	3	
10	V _{EER}	Receiver ground	1	
11	V _{EER}	Receiver ground	1	
12	RD-	Inv. Received Data CML Output, internal AC Coupling	3	Note 5
13	RD+	Received Data CML Output, internal AC Coupling	3	Note 5
14	V _{EER}	Receiver ground	1	
15	V _{CCR}	Receiver Power Supply	2	
16	V _{CCT}	Transmitter Power Supply	2	
17	V _{EET}	Transmitter Ground	1	
18	TD+	Transmit Data LVPECL Input, Internal DC Coupling	3	Note 6
19	TD-	Inv. Transmit Data LVPECL Input, Internal DC Coupling	3	Note 6
20	V _{EET}	Transmitter Ground	1	

Notes:

Plug Seq.: Pin engagement sequence during hot plugging.

- 1) TX Fault is an open collector output, which should be pulled up with a 4.7k~10kΩ resistor on the host board to a voltage between 2.0V and V_{cc}+0.3V. Logic 0 indicates normal operation; Logic 1 indicates a laser fault of some kind. In the low



state, the output will be pulled to less than 0.8V.

- 2) BURST is a TTL input. When it is low, LD is on; when it is high, LD is off.
- 3) Mod-Def 0,1,2. These are the module definition pins. They should be pulled up with a 4.7k~10kΩ resistor on the host board.
The pull-up voltage shall be VccT or VccR.
Mod-Def 0 is grounded by the module to indicate that the module is present
Mod-Def 1 is the clock line of two wire serial interface for serial ID
Mod-Def 2 is the data line of two wire serial interface for serial ID
- 4) SD is an open collector output, which should be pulled up with a 4.7k~10kΩ resistor. Pull up voltage between 2.0V and Vcc+0.3V. Logic 0 indicates loss of signal; Logic 1 indicates normal operation. In the low state, the output will be pulled to less than 0.8V.
- 5) RD-/+ : These are the differential receiver outputs. They are internally AC-coupled 100 differential lines which should be terminated with 100Ω (differential) at the user SERDES.
- 6) TD-/+ : These are the differential transmitter inputs. They are internally DC-coupled, differential lines with 100Ω differential termination inside the module.

Recommend Application Circuit

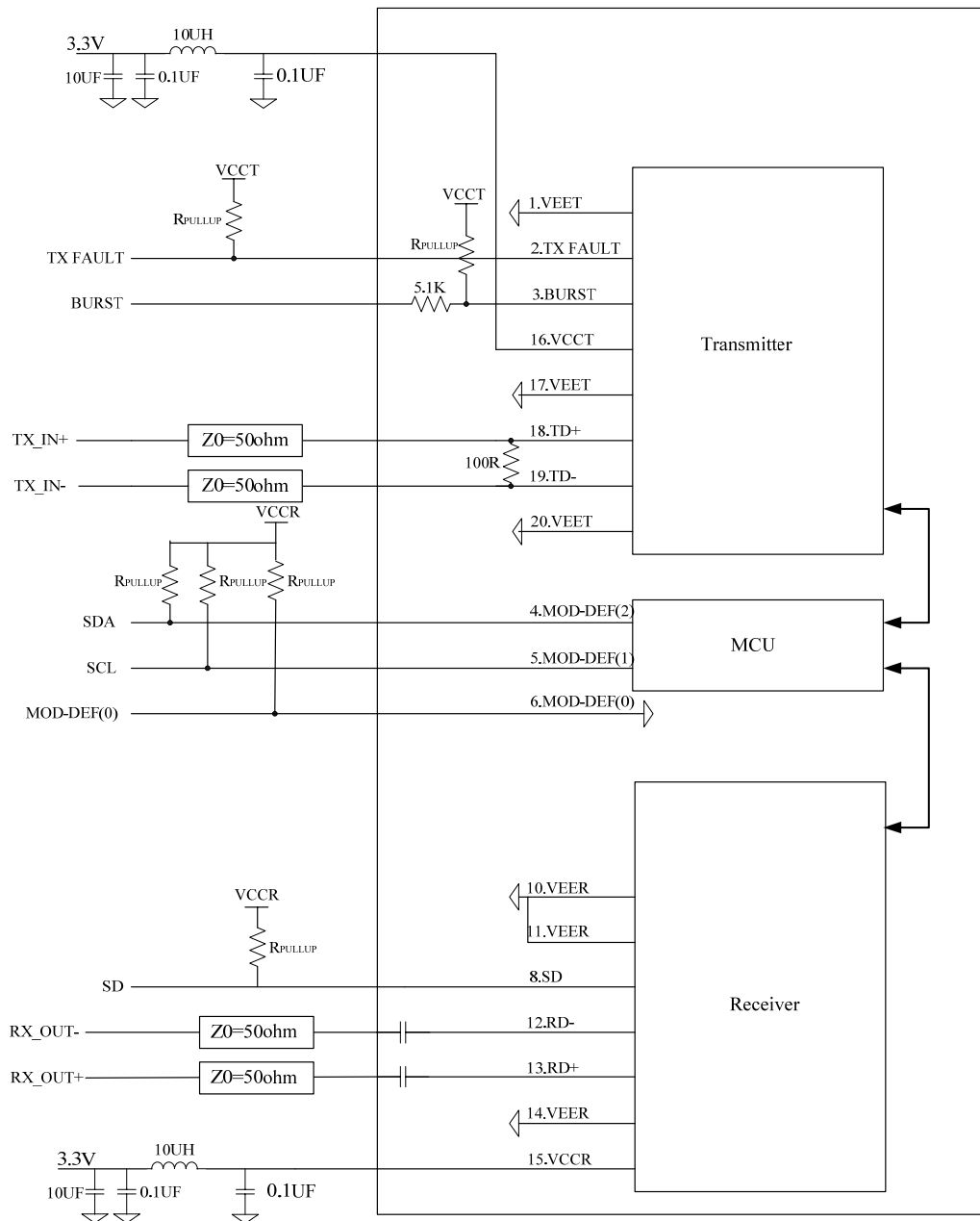

Mechanical Dimensions

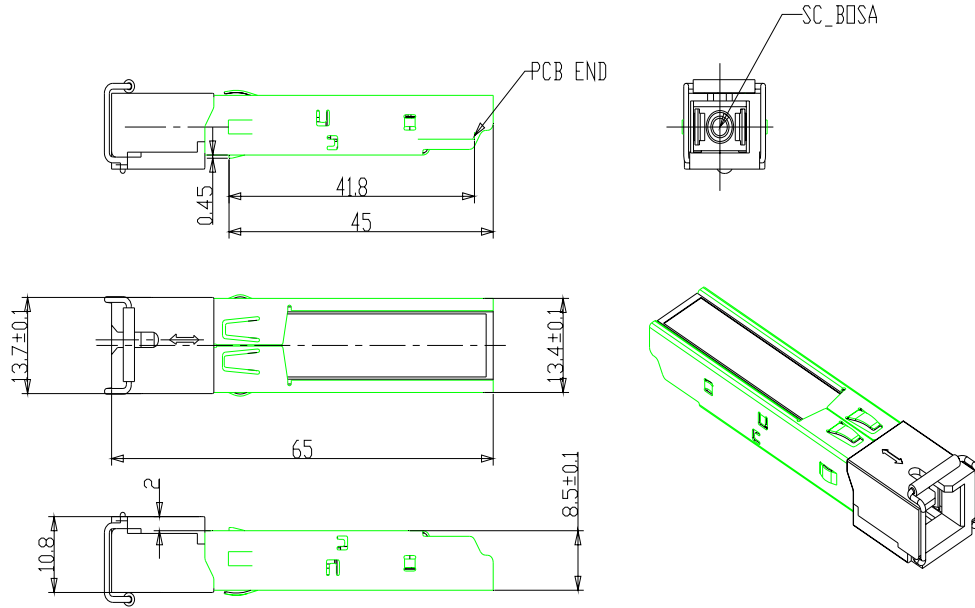

Ordering information

Part Number	Product Description
GB-GPON-ONU-1-2G	Tx1310nm, Rx1490nm, 1.25Gbps/2.5Gbps, Class C+, 0°C ~ +70°C with Digital Diagnostic Monitoring

E-mail: sales@GB-Link.com

Web : <http://www.GB-Link.com>