



GB-GEPON-OLT-2-1G

TURBO-GEPON SFP OLT Transceiver

Features

- ◆ Single Fiber Transceiver with single mode SC receptacle
- ◆ 1490nm continuous-mode 2.5G/s transmitter with DFB laser
- ◆ 1310nm burst-mode 1.25G/s receiver with APD-TIA
- ◆ Single 3.3V power supply
- ◆ LVPECL compatible data input /output
- ◆ Burst mode received signal strength indication (RSSI) output
- ◆ Support more than 22dB dynamic range
- ◆ Complies with IEEE Std 802.3ah™ -2004 1000BASE-PX20
- ◆ Digital diagnostic interface compliant with SFF-8472 Rev 9.4 ,
- ◆ Complies with RoHS directive (2002/95/EC)
- ◆ Operating case temperature:
Standard : 0 to +70°C

Applications

- ◆ Gigabit Ethernet Passive Optical Network (GEPON) OLT

Description

The GB-GEPON-OLT-2-1G transceiver is the high performance module for single fiber by using 1490nm continuous-mode transmitter and 1310nm burst-mode receiver. It is optical line terminal(OLT) for IEEE Std 802.3ah™ -2004 1000BASE-PX20. The optical transceiver is compliant with the Small Form-Factor Pluggable (SFP) Multi-Source Agreement (MSA).

The transmitter section uses a 1490nm DFB LD with automatic power control (APC) function and temperature compensation circuitry to ensure stable extinction ratio over all operating temperature range. and is Class I laser compliant IEC825 and CDRH standards. The receiver has a hermetically packaged APD-TIA (trans-impedance amplifier) pre-amplifier and a limiting amplifier with LVPECL



compatible differential outputs.

The receiver also supports burst mode RSSI output which is enabled by a trigger. Burst mode RSSI function can satisfy system the demand of monitoring the power from any ONU.

Absolute Maximum Ratings

Parameter	Symbol	Min.	Max.	Units	Notes
Storage Temperature	Tst	-40	+85	°C	-
Operating Case Temperature	Tc	0	70	°C	-
Operating Humidity	RH	5	90	%	Non-condensing
Input Voltage	-	GND	Vcc	V	-
Power Supply Voltage	Vcc-Vee	0	3.6	V	-

Recommended Operating Conditions

Parameter		Symbol	Min	Typical	Max	Unit
Operating Case Temperature	Standard	Tc	0	-	+70	°C
Power Supply Voltage		Vcc	3.13	3.3	3.47	V
Power Supply Current		Icc	-	-	500	mA

Optical and Electrical Characteristics

Parameter	Symbol	Min	Typical	Max	Unit	Notes
Transmitter						
Data Rate			2.5		Gb/S	
Centre Wavelength	λ_c	1480		1500	nm	
Spectral Width	$\Delta\lambda$		0.4	1	nm	
Side Mode Suppression Ratio	SMSR	30			dB	
Average Output Power(BOL)	Pout	3		7	dBm	1
Average Output Power(EOL)	Pout	2		7	dBm	1
Extinction Ratio	ER	9			dB	
Average Launch Power-OFF Transmitter	Poff			-40	dBm	



Optical Eye Diagram		Compliant with IEEE802.3ah-2004 PX20				
Data Input Swing Differential	V_{IN}	200		2400	mV	2
Input Differential Impedance	Z_{IN}	90	100	110	Ω	
TX Disable	Disable	2.0		Vcc	V	
	Enable	0		0.8	V	
TX Fault	Fault	2.0		Vcc	V	
	Normal	0		0.8	V	
Receiver						
Data Rate			1.25		Gb/S	
Centre Wavelength	λ_c	1260		1360	nm	
Receiver Sensitivity	Sen			-28	dBm	3
Receiver Overload	Sat	-6			dBm	3
Receiver Burst Dynamic Range		22			dB	
Receiver Reflectance				-20	dB	
Data Output Voltage - High	VOH	VccR -1.05		VccR - 0.85	V	4
Data Output Voltage - Low	VOL	VccR -1.84		VccR - 1.60	● V	4
LOS De-assert Level	LOS_D			-29	dBm	
LOS Assert Level	LOS_A	-45			dBm	
LOS Detect Hysteresis		1		6	dBm	
LOS_Det High		2.0		VCC	V	
LOS_Det Low		0		0.8	V	
LOS De-assert Time	LOS_D T			500	ns	
LOS Assert Time	LOS_A T			500	ns	
Receiver Power DDM (RSSI) Error	RXDDM			+/-3	dBm	

Notes:

1. The optical power is launched into SMF.



2. PECL input, internally AC-coupled and terminated.
3. Measured with a PRBS 2⁷-1 test pattern @1250Mbps, BER ≤1×10⁻¹⁰.
4. Internally DC-coupled.

Diagnostics Specification

Parameter	Range	Unit	Accuracy	Calibration
Temperature	0 to +70	°C	±3°C	Internal / External
Voltage	3.0 to 3.6	V	±3%	Internal / External
Bias Current	0 to 100	mA	±10%	Internal / External
TX Power	2 to 7	dBm	±3dB	Internal / External
RX Power	-28 to -6	dBm	±3dB	Internal / External

Timing Characteristics for Digital RSSI

Parameter	Symbol	Min.	TYP	MAX	UNITS
Trigger delay	Td	300			ns
Sample time	Ts	600			ns
Internal I2C Delay	TI2C			500	us
Digital RSSI		Figure 1			

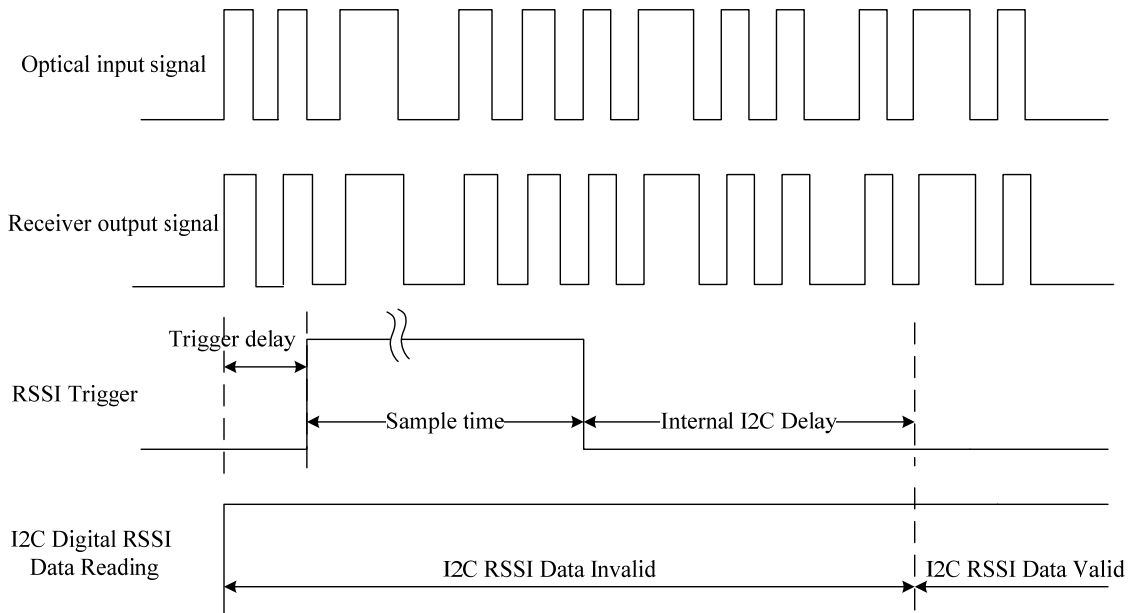

Figure 1 Digital RSSI Timing

Digital Diagnostic Memory Map

The transceivers provide serial ID memory contents and diagnostic information about the present operating conditions by the 2-wire serial interface (SCL, SDA).

The diagnostic information with internal calibration or external calibration all are implemented, including received power monitoring, transmitted power monitoring, bias current monitoring, supply voltage monitoring and temperature monitoring.

The digital diagnostic memory map specific data field defines as following.

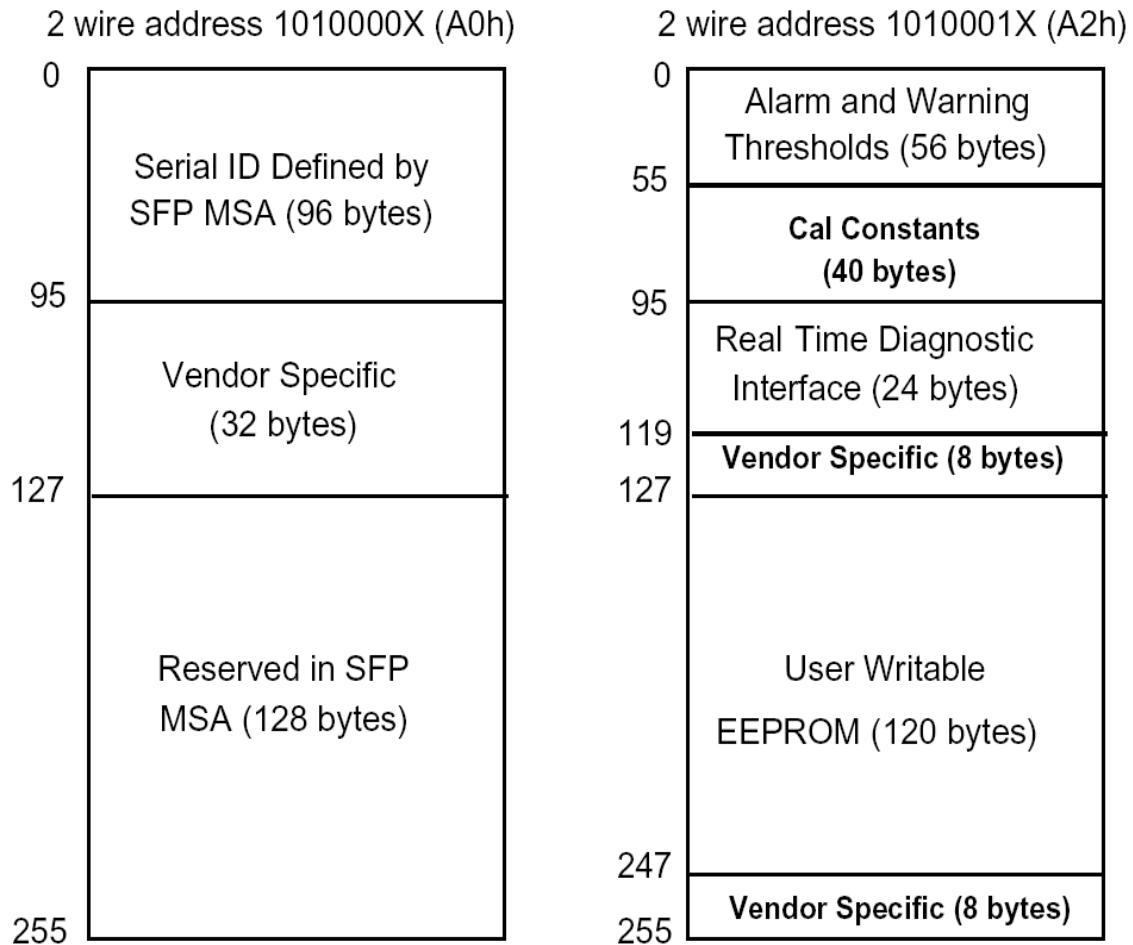

Pin Definitions

Pin Diagram

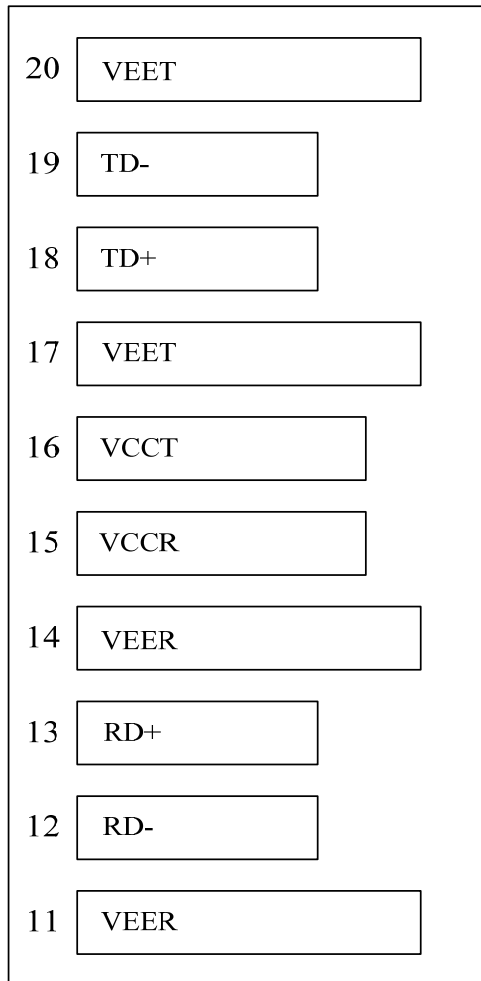

Top of Board

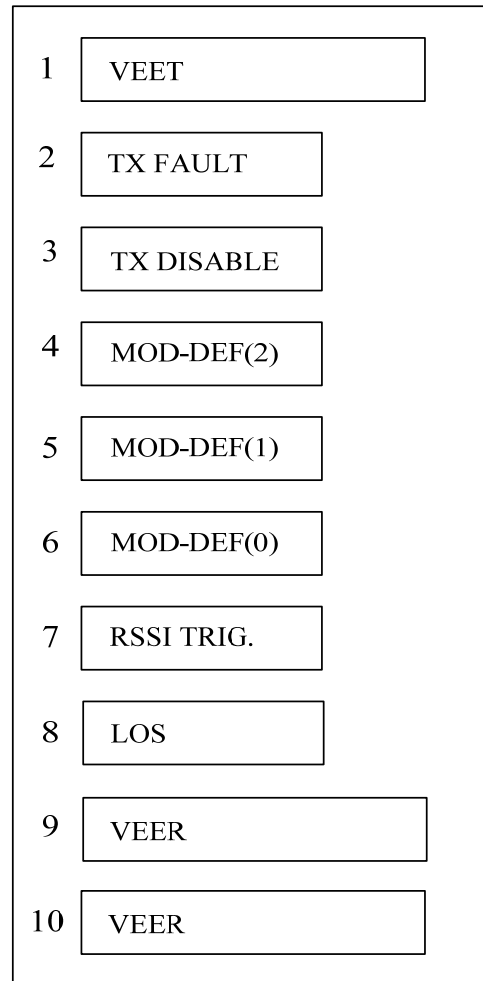

Bottom of Board

Pin Descriptions

Pin	Signal Name	Description	Plug Seq.	Notes
1	V _{EET}	Transmitter Ground	1	
2	TX FAULT	Transmitter Fault Indication	3	Note 1

3	TX DISABLE	Transmitter Disable	3	Note 2
4	MOD_DEF(2)	SDA Serial Data Signal	3	Note 3
5	MOD_DEF(1)	SCL Serial Clock Signal	3	Note 3
6	MOD_DEF(0)	TTL Low	3	Note 3
7	RSSI TRIG.	CMOS input. Assert high at the beginning of the monitored burst package, at least 600ns in duration	3	Note 4
8	LOS	Burst signal detect	3	Note 5
9	V _{EER}	Receiver ground	1	
10	V _{EER}	Receiver ground	1	
11	V _{EER}	Receiver ground	1	
12	RD-	Inv. Received Data Out	3	Note 6
13	RD+	Received Data Out	3	Note 6
14	V _{EER}	Receiver ground	1	
15	V _{CCR}	Receiver Power Supply	2	
16	V _{CCT}	Transmitter Power Supply	2	
17	V _{EET}	Transmitter Ground	1	
18	TD+	Transmit Data In	3	Note 7
19	TD-	Inv. Transmit Data In	3	Note 7
20	V _{EET}	Transmitter Ground	1	

Notes:

Plug Seq.: Pin engagement sequence during hot plugging.

- 1) TX Fault is an open collector output, which should be pulled up with a 4.7k~10kΩ resistor on the host board to a voltage between 2.0V and V_{cc}+0.3V. Logic 0 indicates normal operation; Logic 1 indicates a laser fault of some kind. In the low state, the output will be pulled to less than 0.8V.
- 2) TX Disable is an input that is used to shut down the transmitter optical output. It is pulled up within the module with a 4.7k~10kΩ resistor. Its states are:

Low (0 to 0.8V):	Transmitter on
(>0.8V, < 2.0V):	Undefined
High (2.0 to 3.465V):	Transmitter Disabled
Open:	Transmitter Disabled



3) Mod-Def 0,1,2. These are the module definition pins. They should be pulled up with a 4.7k~10kΩ resistor on the host board. The pull-up voltage shall be VccT or VccR.

Mod-Def 0 is grounded by the module to indicate that the module is present

Mod-Def 1 is the clock line of two wire serial interface for serial ID

Mod-Def 2 is the data line of two wire serial interface for serial ID

4) RSSI TRIG is a CMOS input. Assert high after 300ns delay time of the beginning of the monitored burst package, at least 600ns in duration.

5) LOS (Loss of Signal) is an open collector/drain output, which should be pulled up with a 4.7K – 10KΩ resistor. Pull up voltage between 2.0V and VccT, R+0.3V. When high, this output indicates the received optical power is below the worst-case receiver sensitivity (as defined by the standard in use). Low indicates normal operation. In the low state, the output will be pulled to < 0.8V.

6) RD-/+ : These are the differential receiver outputs. They are internally DC-coupled 100 differential lines which should be terminated with 100Ω (differential) at the user SERDES.

7) TD-/+ : These are the differential transmitter inputs. They are internally AC-coupled, differential lines with 100Ω differential termination inside the module.

Recommended Interface Circuit

F/2,D Building, Fuxin Industrial Area, 3rd Yangxia Street, Shajin Town, Shenzhen, China

Tel: 86-755-27683696

Fax: 86-755-36652839

v1.1

[Http://www.GB-Link.com](http://www.GB-Link.com)

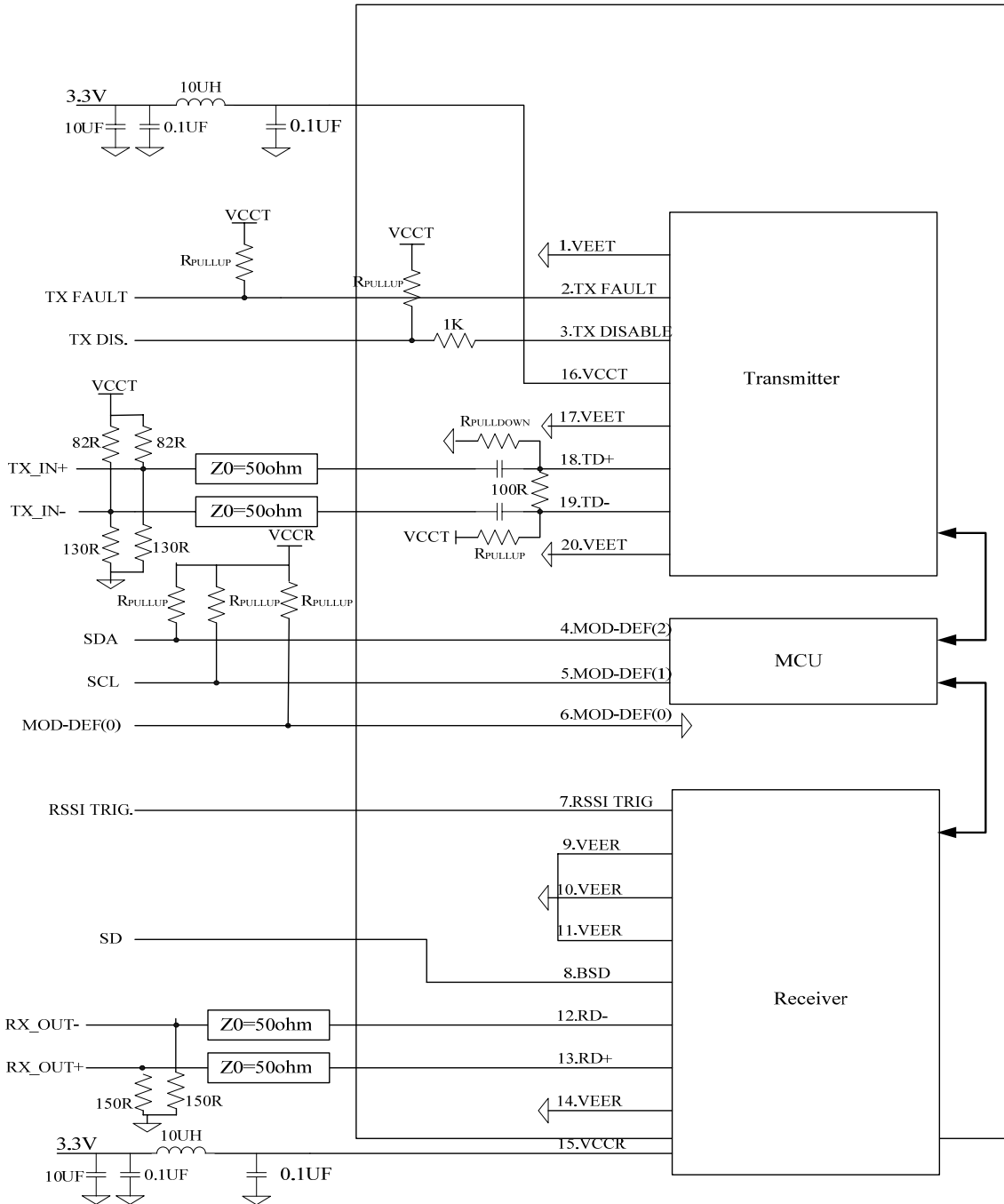

Mechanical Dimensions

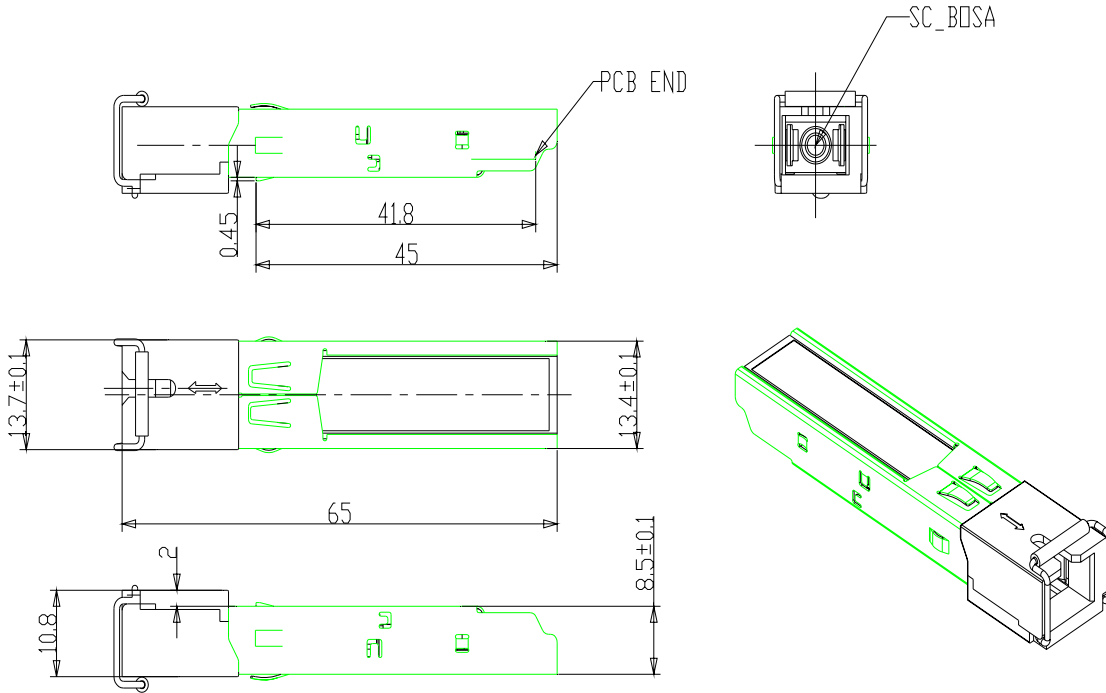

Ordering information

Part Number	Product Description
GB-GEAPON-OLT-2-1G	Tx1490nm, Rx1310nm ,2.5Gbps/1.25Gbps, 1000BASE-PX20, 0°C ~ +70°C With Digital Diagnostic Monitoring

E-mail: sales@GB-Link.com

Web : <http://www.GB-Link.com>