


---

## 8.5Gb/s SFP+ Fiber Channel Optical Transceiver GB-SFP+8G31-LRS

### Features

- ◆ Up to 8.5Gb/s bi-directional data links
- ◆ Hot Pluggable SFP+ footprint
- ◆ Built-in digital diagnostic functions
- ◆ 1310nm DFB laser transmitter
- ◆ Duplex LC connector
- ◆ Up to 10km on 9/125um SMF
- ◆ Single 3.3V power supply
- ◆ Operating case temperature: 0 to 70°C
- ◆ RoHS6 compliant (lead free) 



### Applications

- ◆ Tri Rate 2.125/4.25/8.5Gbs Fiber Channel

### Product description

GB-Link GB-SFP+8G31-LRS SFP+ transceivers are designed for use in Fiber Channel links up to 8.5 Gb/s data rate and up to 10 km link length. They are compliant with FCPI-4 Rev. 8.00 and SFF-8472 Rev 10.2, and compatible with SFF-8432 and applicable portions of SFF-8431 Rev. GB-Link GB-SFP+8G31-LRS Digital diagnostics functions are available via a 2-wire serial interface, as specified in SFF-8472, which allows real-time access to device operating parameters such as transceiver temperature, laser bias current, transmitted optical power, received optical power and transceiver supply voltage. 3.0. The product is RoHS compliant and lead-free per Directive 2002/95/EC.



### Absolute Maximum Ratings

These values represent the damage threshold of the module. Stress in excess of any of the individual Absolute Maximum Ratings can cause immediate catastrophic damage to the module even if all other parameters are within Recommended Operating Conditions.

Parameters	Symbol	Min.	Max.	Unit
Supply Voltage	V <sub>CC</sub>	0	+3.8	V
Storage Temperature	T <sub>c</sub>	-40	+85	°C
Operating Case Temperature	T <sub>c</sub>	0	+70	°C
Relative Humidity	RH	0	85	%

### Operating Conditions

Parameter	Symbol	Min.	Typical	Max	Unit
Supply Voltage	V <sub>CC</sub>	3.0	3.3	3.6	V
Supply current	I <sub>CC</sub>		200	300	mA
Operating Case Temperature	T <sub>c</sub>	0	25	70	°C
Module Power Dissipation	P <sub>m</sub>	-	0.7	1.1	W

#### Notes:

1. Supply current is shared between VCCTX and VCCR<sub>X</sub>.
2. In-rush is defined as current level above steady state current requirements.

### Low Speed Characteristics

Parameter	Symbol	Min.	Typical	Max	Unit
Power Consumption				1	W
TX_Fault,RX_LOS	VOL	0		0.4	V
	VOH	Host_Vcc-0.5		Host_Vcc+0.3	V
TX_DIS	VIL	-0.3		0.8	V
	VIH	2.0		VCCT+0.3	V
RS0,RS1	VIL	-0.3		0.8	V
	VIH	2.0		VCCT+0.3	V



### Optical characteristics

Parameter	Symbol	Min.	Typical	Max	Unit	Ref.
<b>Transmitter</b>						
Output Opt. Power, 8.5 Gb/s	$P_o$	-8.4		+0.5	dBm	1
Optical Wavelength	$\lambda$	1285		1345	nm	2
Side Mode Suppression Ratio	$SMSR_{min}$	30			dB	2
Optical Modulation Amplitude	OMA	290			uW	2,3
Transmitter and Dispersion Penalty, 8.5 Gb/s	TDP			3.2	dB	4
<b>Receiver</b>						
Unstressed Receiver OMA Sensitivity, 8.5 Gb/s	$RSENSr$			0.042	mW	5
Average Received Power	$RX_{MAX}$			+0.5	dBm	
Optical Center Wavelength	$\lambda_C$	1260		1360	nm	
Return Loss		12			dB	
LOS De-Assert	$LOS_D$			-18	dBm	
LOS Assert	$LOS_A$	-30			dBm	
LOS Hysteresis		0.5			dB	

Notes:

1. High Bandwidth Mode. Class 1 Laser Safety per FDA/CDRH and EN (IEC) 60825 regulations.
2. Also specified to meet curves in FC-PI-4 Rev 8.001 Figures 21, 22, and 23, which allow trade-off between wavelength, spectral width and OMA.
3. Equivalent extinction ratio specification for Fibre Channel. Allows smaller ER at higher average power.
4. For 8.5 Gb/s operation, Jitter values for gamma T and gamma R are controlled by TDP and stressed receiver sensitivity.
5. Measured with conformance signals defined in FC-PI-4 Rev. 8.00 specifications. Value in OMA. Measured with PRBS 27-1 at 10-12 BER.

## Electrical characteristics

Parameter	Symbol	Min.	Typical	Max	Unit	Ref.
Supply Voltage	$V_{CC}$	3.00		3.60	V	1
Supply Voltage	$I_{CC}$		200	300	mA	1
<b>Transmitter</b>						
Input differential impedance	$R_{in}$		100		$\Omega$	2
Single ended data input swing	$V_{in,pp}$	150		900	mV	
Transmit Disable Voltage	$V_D$	2		$V_{CC}$	V	
Transmit Enable Voltage	$V_{EN}$	Vee		Vee+0.8	V	3
<b>Receiver</b>						
Single ended data output swing	$V_{out,pp}$	300		800	mV	4
Data output rise/fall time,8.5 Gb/s	$T_{r,tf}$			60	ps	5
LOS Fault	$V_{LOS\ fault}$	2		$V_{CC\ HOST}$	V	6
LOS Normal	$V_{LOS\ norm}$	Vee		Vee+0.8	V	6

Notes:

1. Module power consumption never exceeds 1W.
2. AC coupled.
3. Or open circuit.
4. Into 100 ohm differential termination.
5. 20 – 80 %.
6. LOS is LVTTTL. Logic 0 indicates normal operation; logic 1 indicates no signal detected.

## General Specifications

Parameter	Symbol	Min.	Typical	Max	Unit	Notes
Data Rate	DR	2.125		8.5	Gb/sec	1
Bit Error Rate	BER			$10^{-12}$		2
Max. Supported Link Length on 9/125 $\mu$ m SMF	L		10		Km	3

Notes:

1. 2x/4x/8x Fibre Channel compliant.
2. Tested with a PRBS 2<sup>7</sup>-1 test pattern.
3. Distances are based on FC-PI-4 Rev. 8.00' and IEEE 802.3 standards.

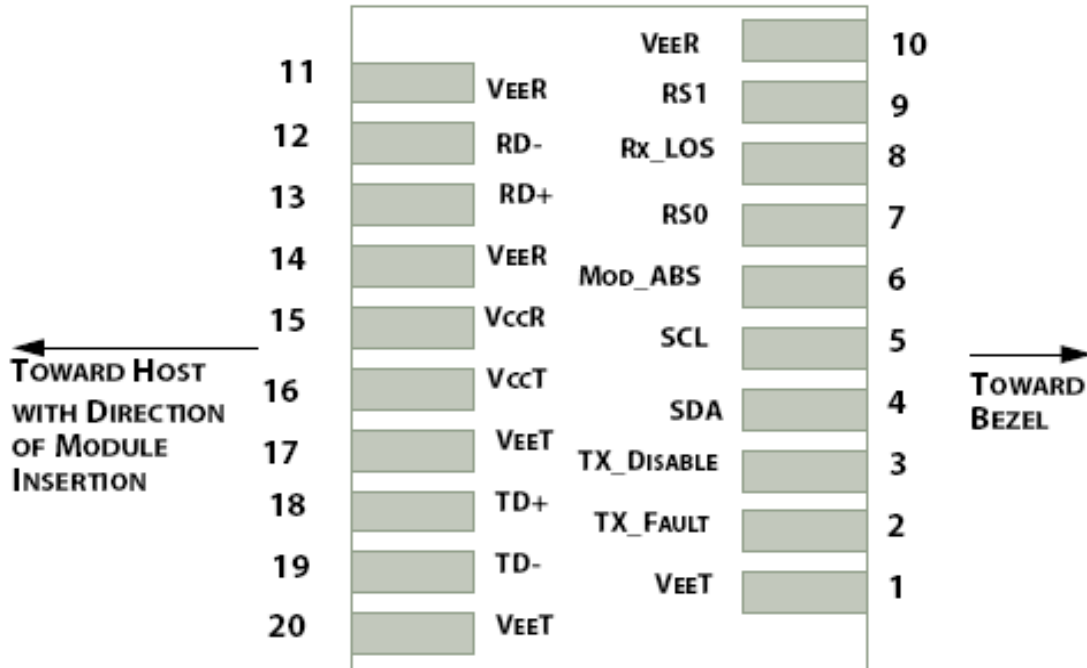


Figure 1: Interface to Host PCB

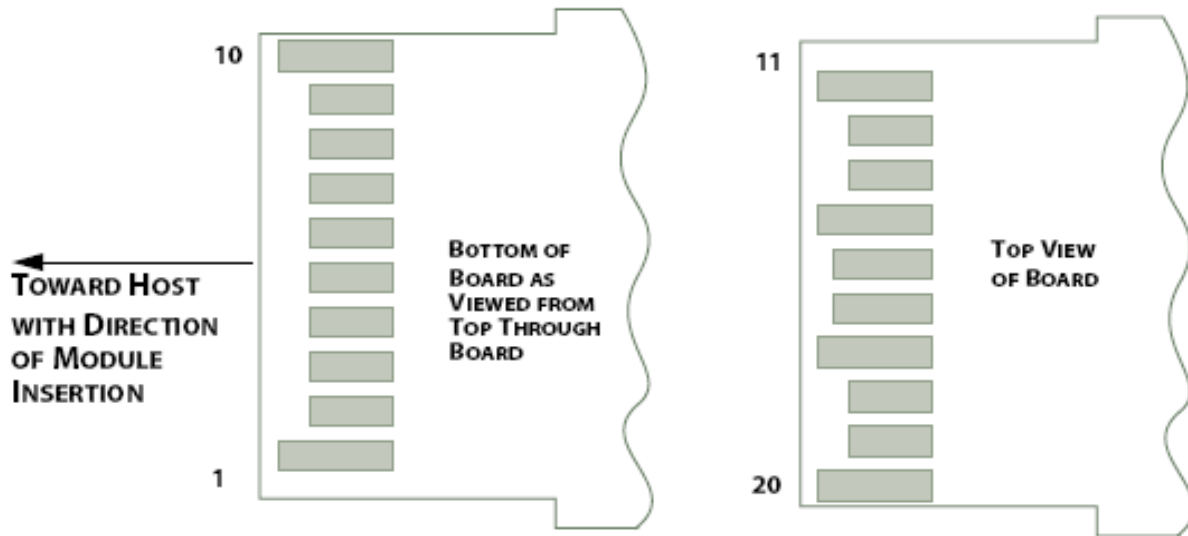


Figure 2: Module Contact Assignment

### Pin definition

Pin	Symbol	Name/Description
1	VEET [1]	Transmitter Ground
2	Tx_FAULT [2]	Transmitter Fault
3	Tx_DIS [3]	Transmitter Disable. Laser output disabled on high or open
4	SDA [2]	2-wire Serial Interface Data Line
5	SCL [2]	2-wire Serial Interface Clock Line
6	MOD_ABS [4]	Module Absent. Grounded within the module
7	RS0 [5]	Rate Select 0
8	RX_LOS [2]	Loss of Signal indication. Logic 0 indicates normal operation
9	RS1 [5]	Rate Select 1
10	VEER [1]	Receiver Ground
11	VEER [1]	Receiver Ground
12	RD-	Receiver Inverted DATA out. AC Coupled

13	RD+	Receiver DATA out. AC Coupled
14	VEER [1]	Receiver Ground
15	VCCR	Receiver Power Supply
16	VCCT	Transmitter Power Supply
17	VEET [1]	Transmitter Ground
18	TD+	Transmitter DATA in. AC Coupled
19	TD-	Transmitter Inverted DATA in. AC Coupled
20	VEET [1]	Transmitter Ground

**Notes:**

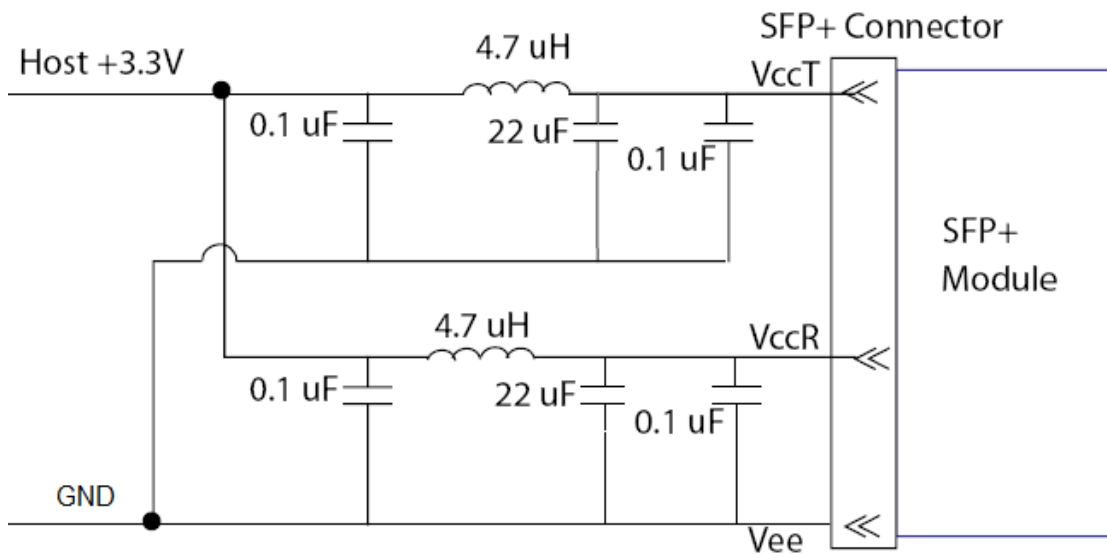
[1] Module circuit ground is isolated from module chassis ground within the module.

[2].should be pulled up with 4.7k – 10k ohms on host board to a voltage between 3.15V and 3.6V.

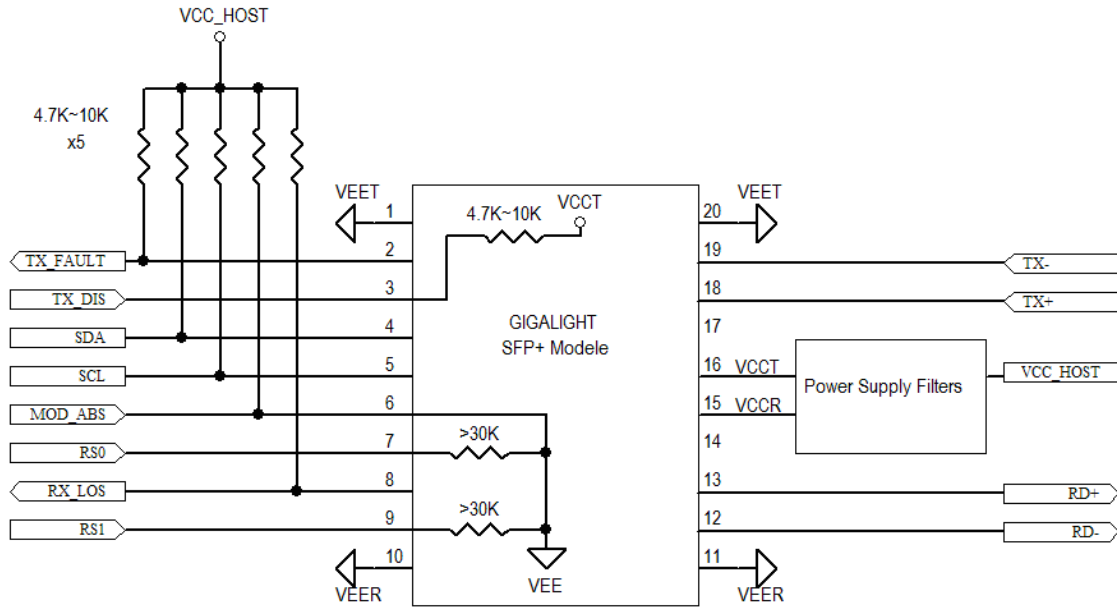
[3]Tx\_Disable is an input contact with a 4.7 kΩ to 10 kΩ pullup to VccT inside the module.

[4]Mod\_ABS is connected to VeeT or VeeR in the SFP+ module. The host may pull this contact up to Vcc\_Host with a resistor in the range 4.7 kΩ to 10 kΩ. Mod\_ABS is asserted “High” when the SFP+ module is physically absent from a host slot.

[5] RS0 and RS1 are module inputs and are pulled low to VeeT with > 30 kΩ resistors in the module.

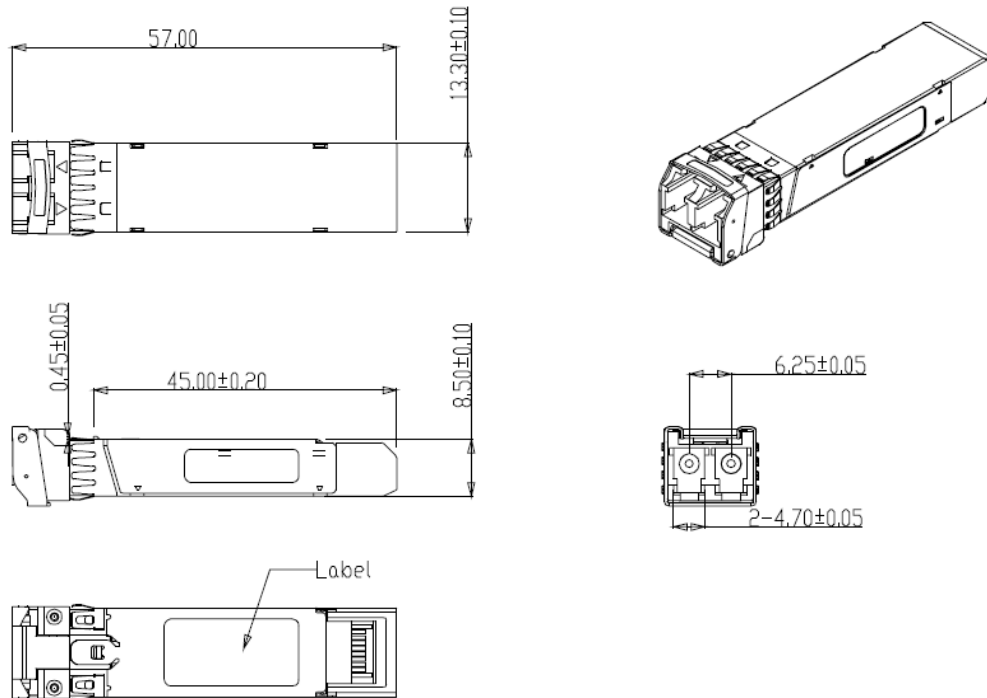


**Figure3. Host Board Power Supply Filters Circuit**



**Figure4. Host-Module Interface**





**Figure5. Mechanical Specifications**

### Regulatory Compliance

GB-LINK SFP+ transceiver is designed to be Class I Laser safety compliant and is certified per the following standards:

Feature	Agency	Standard	Certificate / Comments
Laser Safety	FDA	CDRH 21 CFR 1040 and Laser Notice No. 50	1120292-000
Product Safety	UL	UL and CUL EN60950-2:2007	E347511
Environmental protection	SGS	RoHS Directive 2002/95/EC	GZ1001008918/CHEM
EMC	WALTEK	EN 55022:2006+A1:2007 EN 55024:1998+A1+A2:2003	WT10093759-D-E-E



深圳市光辉通信技术有限公司  
Shenzhen GB-Link Technology Co., LTD  
[Http://www.GB-Link.com](http://www.GB-Link.com)

10

---

### Ordering information

Part Number	Product Description
GB-SFP+8G31-LRS	1310nm, 2.125/4.25/8.5Gbs, SFP+ 10km, 0°C ~ +70°C

E-mail: [sales@GB-Link.com](mailto:sales@GB-Link.com)

Web : <http://www.GB-Link.com>

---

F/2,D Building, Fuxin Industrial Area, 3rd Yangxia Street, Shajin Town, Shenzhen, China

Tel: 86-755-27683696

Fax: 86-755-36652839

v1.1

[Http://www.GB-Link.com](http://www.GB-Link.com)