

## GB-GBIC-C-24XX-40 GBIC 1.25G CWDM 40KM Transceiver

### PRODUCT FEATURES

- Up to 1.25Gb/s data links
- DFB laser transmitter
- PIN photo-detector.
- Up to 40km on 9/125 $\mu$ m SMF
- GBIC footprint
- Duplex SC/UPC type pluggable optical interface
- Low power dissipation
- Metal enclosure, for lower EMI
- RoHS compliant and lead-free
- Single +5V power supply
- Compliant with SFF-8472
- Case operation temperature: 0°C to +70°C



### APPLICATIONS

- Switch to Switch Interface
- Gigabit Ethernet
- Switched Backplane Applications
- Router/Server Interface

- Other Optical Links

## PRODUCT DESCRIPTION

GB-LINK's GB-GBIC-C-24XX-40 transceiver is a high performance and cost effective module for serial optical data communication applications. The interface converters meet the GBIC Standard Rev.5.5. This module is designed for single mode fiber and operates at the wavelength of 1XX0nm. The transceiver consists of four sections : the LD driver, the limiting amplifier, the DFB laser and the PIN photo-detector. The module data link up to 40Km in 9/125um single mode fiber .

The optical output can be disabled by a TTL logic high-level input of Tx Disable. Tx Fault is provided to indicate that degradation of the laser. Loss of signal(LOS) output is provided to indicate the loss of an input optical signal of receiver or the link status with partner.

## PRODUCT SELECTION

GB-GBIC-C-24XX-40

Wavelength	xx	Wavelength	xx	Wavelength	xx
1270 nm	27	1390 nm	39	1510 nm	51
1290 nm	29	1410 nm	41	1530 nm	53
1310 nm	31	1430 nm	43	1550 nm	55
1330 nm	33	1450 nm	45	1570 nm	57
1350 nm	35	1470 nm	47	1590 nm	59
1370 nm	37	1490 nm	49	1610 nm	61

## I. Pin Descriptions

Pin	Symbol	I/O Type	Functional Description
1	RX_LOS	Output	Receiver Loss of Signal, Logic high, Open collector compatible 4.7K to 10K Ohm pulls up to VDDT on host.
2	RGND		Receiver Ground
3	RGND		Receiver Ground
4	MOD_DEF(0)	Output	Module Definition 0 TTL Low
5	MOD_DEF(1)	Input	Module Definition 1 Two wire serial ID interface SCL, 4.7K to 10K Ohm pull up to VDDT on host
6	MOD_DEF(2)	I/O	Module Definition 2 Two wire serial ID interface SDA, 4.7K to 10K Ohm pull up to VDDT on host
7	TX_DISABLE	Input	Transmitter Disable – Module disable on high or open (No Used)
8	TGND		Transmitter Ground
9	TGND		Transmitter Ground
10	TX_FAULT	Output	Transmitter Fault Indication, Logic high, open collector Compatible , 4.7K to 10K Ohm pull up to VDDT on host
11	RGND		Receiver Ground
12	-RX_DAT	Output	Inverse Received Data Out, Differential PECL, at AC couple
13	+RX_DAT	Output	Received Data Out, Differential PECL, at AC couple
14	RGND		Receiver Ground
15	VDDR	Input	Receiver Power
16	VDDT	Input	Transmitter Power
17	TGND		Transmitter Ground
18	+TX_DAT	Input	Transmitter Data In, Differential PECL, AC couple
19	-TX_DAT	Input	Inverse Transmitter Data In, Differential PECL, AC couple
20	TGND		Transmitter Ground

3

## II. Absolute Maximum Ratings

Parameter	Symbol	Min.	Typ.	Max.	Unit	Note
Storage Temperature	Ts	-40		85	°C	
Storage Ambient Humidity	HA	5		95	%	
Power Supply Voltage	VCC	0		6	V	
Signal Input Voltage		0		Vcc	V	
Receiver Damage Threshold		5			dBm	

## III. Recommended Operating Conditions

Parameter	Symbol	Min.	Typ.	Max.	Unit	Note	
Case Operating Temperature	Tcase	0		70	°C		
Ambient Humidity	HA	5		70	%	Non-condensing	
Power Supply Voltage	VCC	4.75	5	5.25	V		
Power Supply Current	ICC			300	mA		
Power Supply Noise Rejection				100	mVp-p	100Hz to 1MHz	
Data Rate			1250/1250		Mbps	TX Rate/RX Rate	
Transmission Distance				40	KM		
Coupled Fiber		Single mode fiber					9/125um SMF

## IV. Specification of Transmitter

Parameter	Symbol	Min.	Typ.	Max.	Unit	Note
Average Output Power	P <sub>OUT</sub>	-5		0	dBm	Note (1)
Extinction Ratio	ER	9			dB	
Center Wavelength	$\lambda_c$	(1XX0)-7.5	1XX0	(1XX0)+7.5	nm	DFB Laser Note (2)
Side Mode Suppression Ratio	SMSR	30			dB	
Spectrum Bandwidth(-20dB)	$\sigma$			1	nm	
Transmitter OFF Output Power	P <sub>OFF</sub>			-45	dBm	
Differential Line Input Impedance	R <sub>IN</sub>	90	100	110	Ohm	
Output Eye Mask	Compliant with IEEE802.3 z (class 1 laser safety)					Note (3)

Note (1): Measure at 2<sup>7</sup>-1 NRZ PRBS pattern.

4

Note (2).“XX” is: 27,29,31,33,35,37,39,41,43,45,47,49,51,53,55,57,59 and 61

Note (3): Transmitter eye mask definition.

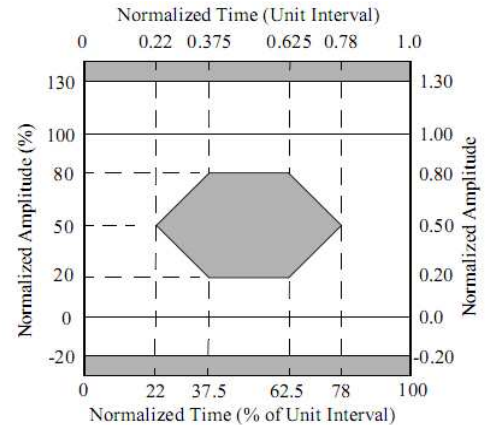

## V. Specification of Receiver

Parameter	Symbol	Min.	Typ.	Max.	Unit	Note
Input Optical Wavelength	$\lambda_{IN}$	1270		1610	nm	PIN-TIA
Receiver Sensitivity	$P_{IN}$			-24	dBm	Note (1)
Input Saturation Power (Overload)	$P_{SAT}$	-3			dBm	
Los Of Signal Assert	$P_A$			-25	dBm	
Los Of Signal De-assert	$P_D$	-38			dBm	Note (2)
LOS Hysteresis	$P_A-P_D$	0.5	2	6	dB	

Note (1): Measured with Light source 1xx0nm, ER=9dB; BER  $\leq 10^{-12}$  @PRBS=2<sup>7</sup>-1 NRZ.

Note (2): When LOS de-asserted, the RX data+/- output is High-level (fixed)

## VI. Electrical Interface Characteristics

Parameter	Symbol	Min.	Typ.	Max.	Unit	Note
<b>Transmitter</b>						
Total Supply Current	$I_{CC}$			A	mA	Note (1)
Transmitter Disable Input-High	$V_{DISH}$	2		$V_{CC}+0.3$	V	
Transmitter Disable Input-Low	$V_{DISL}$	0		0.8	V	
Transmitter Fault Input-High	$V_{DISL}$	2		$V_{CC}+0.3$	V	
Transmitter Fault Input-Low	$V_{TXFH}$	0		0.8	V	
<b>Receiver</b>						
Total Supply Current	$I_{CC}$			B	mA	Note (1)
LOS Output Voltage-High	$V_{LOSH}$	2		$V_{CC}+0.3$	V	LVTTL
LOS Output Voltage-Low	$V_{LOSL}$	0		0.8	V	



深圳市光辉通信技术有限公司  
Shenzhen GB-Link Technology Co., LTD  
[Http://www.GB-Link.com](http://www.GB-Link.com)

---

Note (1): A (TX) + B (RX) = 300mA (Not include termination circuit)

## VII. Mechanical Specifications (Unit: mm)

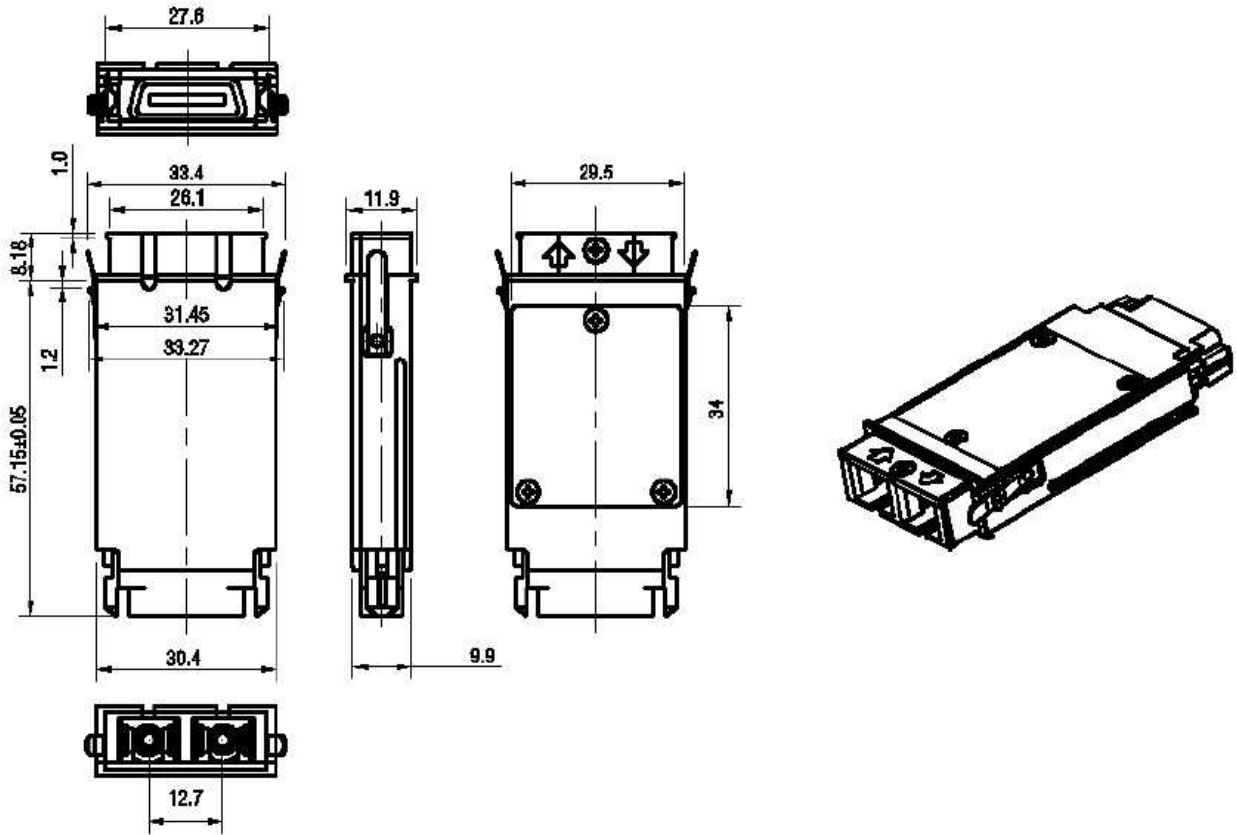

## GB-GBIC-C-24XX-40

### Appendix A. Document Revision

Version No.	Date	Description
1.0	2011-4-26	Preliminary datasheet
2.0	2011-09-27	Update format and company's logo