

GB-GBIC-80 GBIC 1.25G 1550nm 80KM Transceiver

PRODUCT FEATURES

- Up to 1.25Gb/s data links
- DFB laser transmitter
- PIN photo-detector
- Up to 80km on 9/125 μ m SMF
- GBIC footprint
- Duplex SC/UPC type pluggable optical interface
- Low power dissipation
- Metal enclosure, for lower EMI
- RoHS compliant and lead-free
- Single +5V power supply
- Compliant with SFF-8472
- Case operation Temperature: 0°C to +70°C



APPLICATIONS

- Switch to Switch Interface
- Gigabit Ethernet
- Switched Backplane Applications
- Router/Server Interface

- Other Optical Links

PRODUCT DESCRIPTION

GB-LINK's GB-GBIC-80 Small Form Factor Pluggable (SFP) transceivers are compatible with the Small Form Factor Pluggable Multi-Sourcing Agreement (MSA). The transceiver consists of four sections: the LD driver, the limiting amplifier, the DFB laser and the PIN photo-detector. The module data link up to 80KM in 9/125um single mode fiber.

The optical output can be disabled by a TTL logic high-level input of Tx Disable. Tx Fault is provided to indicate that degradation of the laser. Loss of signal (LOS) output is provided to indicate the loss of an input optical signal of receiver or the link status with partner.

I. Pin Descriptions

Pin	Symbol	I/O Type	Functional Description
1	RX_LOS	Output	Receiver Loss of Signal, Logic high, Open collector compatible 4.7K to 10K Ohm pulls up to VDDT on host.
2	RGND		Receiver Ground
3	RGND		Receiver Ground
4	MOD_DEF(0)	Output	Module Definition 0 TTL Low
5	MOD_DEF(1)	Input	Module Definition 1 Two wire serial ID interface SCL, 4.7K to 10K Ohm pull up to VDDT on host
6	MOD_DEF(2)	I/O	Module Definition 2 Two wire serial ID interface SDA, 4.7K to 10K Ohm pull up to VDDT on host
7	TX_DISABLE	Input	Transmitter Disable – Module disable on high or open (No Used)
8	TGND		Transmitter Ground
9	TGND		Transmitter Ground
10	TX_FAULT	Output	Transmitter Fault Indication, Logic high, open collector Compatible, 4.7K to 10K Ohm pull up to VDDT on host
11	RGND		Receiver Ground



12	-RX_DAT	Output	Inverse Received Data Out, Differential PECL, at AC couple
13	+RX_DAT	Output	Received Data Out, Differential PECL, at AC couple
14	RGND		Receiver Ground
15	VDDR	Input	Receiver Power
16	VDDT	Input	Transmitter Power
17	TGND		Transmitter Ground
18	+TX_DAT	Input	Transmitter Data In, Differential PECL, AC couple
19	-TX_DAT	Input	Inverse Transmitter Data In, Differential PECL, AC couple
20	TGND		Transmitter Ground

II. Absolute Maximum Ratings

Parameter	Symbol	Min.	Typ.	Max.	Unit	Note
Storage Temperature	Ts	-40		85	°C	
Storage Ambient Humidity	HA	5		95	%	
Power Supply Voltage	VCC	0		6	V	
Signal Input Voltage		0		Vcc	V	
Receiver Damage Threshold		5			dBm	

III. Recommended Operating Conditions

Parameter	Symbol	Min.	Typ.	Max.	Unit	Note
Case Operating Temperature	Tcase	0		70	°C	
Ambient Humidity	HA	5		70	%	Non-condensing
Power Supply Voltage	VCC	4.75	5	5.25	V	
Power Supply Current	ICC			300	mA	
Power Supply Noise Rejection				100	mVp-p	100Hz to 1MHz
Data Rate			1250/1250		Mbps	TX Rate/RX Rate
Transmission Distance				80	KM	
Coupled Fiber			Single mode fiber			9/125um SMF

IV. Specification of Transmitter

Parameter	Symbol	Min.	Typ.	Max.	Unit	Note
Average Output Power	P _{OUT}	0		5	dBm	Note (1)
Extinction Ratio	ER	9			dB	
Center Wavelength	λ_c	1530	1550	1570	nm	DFB Laser
Side Mode Suppression Ratio	SMSR	30			dB	
Spectrum Bandwidth(-20dB)	σ			1	nm	
Transmitter OFF Output Power	P _{off}			-45	dBm	
Differential Line Input Impedance	R _{IN}	90	100	110	Ohm	
Output Eye Mask 3		Compliant with IEEE802.3 z (class 1 laser safety)				Note (2)

Note (1): Measure at 2^7-1 NRZ PRBS pattern.

Note (2): Transmitter eye mask definition.

V. Specification of Receiver

Parameter	Symbol	Min.	Typ.	Max.
Input Optical Wavelength	λ_{IN}	1270		
Receiver Sensitivity	P_{IN}			
Input Saturation Power (Overload)	P_{SAT}	-3		
Los Of Signal Assert	P_A			
Los Of Signal De-assert	P_D	-38		
LOS Hysteresis	P_A-P_D	0.5		

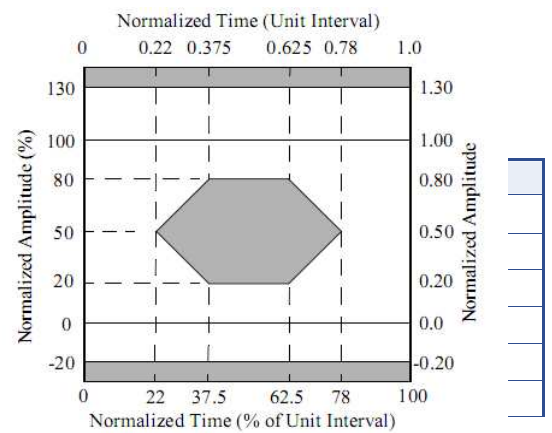

Note (1): Measured with Light source 1550nm, ER=9dB; BER $\leq 10^{-12}$ @PRBS= 2^7-1 NRZ.

Note (2): When LOS de-asserted, the RX data +/- output is High-level (fixed)

VI. Electrical Interface Characteristics

Parameter	Symbol	Min.	Typ.	Max.	Unit	Note
Transmitter						
Total Supply Current	I_{CC}			A	mA	Note (1)
Transmitter Disable Input-High	V_{DISH}	2		$V_{CC}+0.3$	V	
Transmitter Disable Input-Low	V_{DISL}	0		0.8	V	
Transmitter Fault Input-High	V_{DISL}	2		$V_{CC}+0.3$	V	
Transmitter Fault Input-Low	V_{TXFH}	0		0.8	V	
Receiver						
Total Supply Current	I_{CC}			B	mA	Note (1)
LOSS Output Voltage-High	V_{LOSH}	2		$V_{CC}+0.3$	V	LVTTTL
LOSS Output Voltage-Low	V_{LOSL}	0		0.8	V	



深圳市光辉通信技术有限公司
Shenzhen GB-Link Technology Co., LTD
[Http://www.GB-Link.com](http://www.GB-Link.com)

Note (1): $A \text{ (TX)} + B \text{ (RX)} = 300\text{mA}$ (Not include termination circuit)

VII. Mechanical Specifications (Unit: mm)

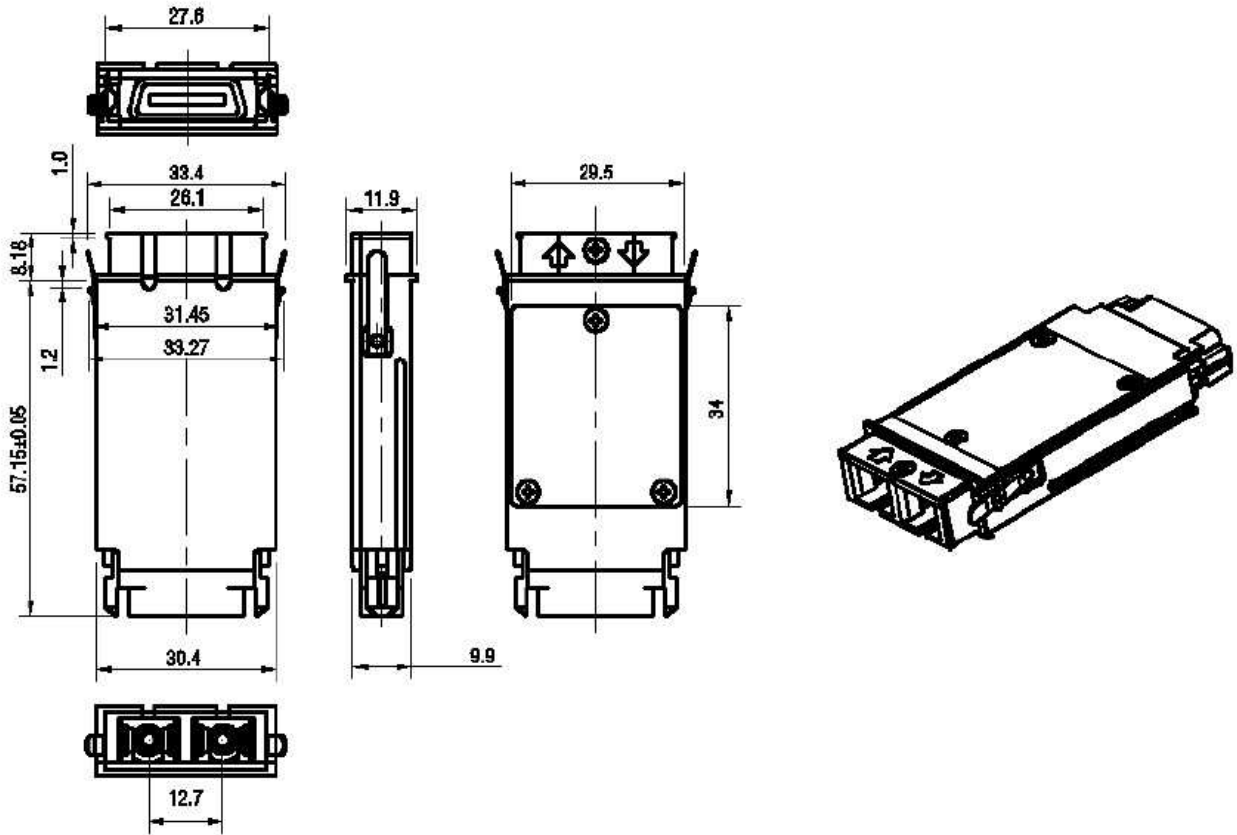

GB-GBIC-80

Appendix A. Document Revision

Version No.	Date	Description
1.0	2011-4-26	Preliminary datasheet
2.0	2011-09-27	Update format and company's logo